

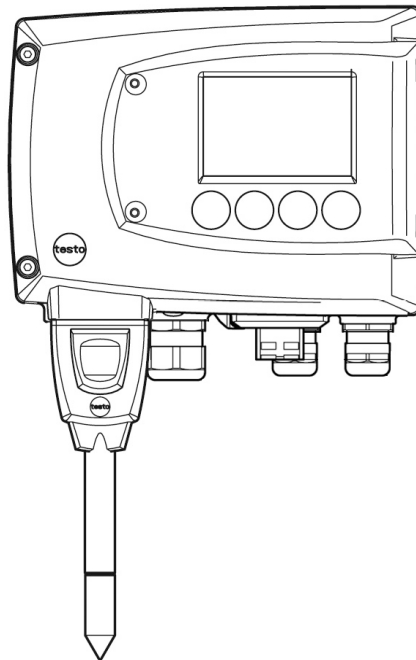

**testo 6681 Ethernet · Humidity transmitter  
with Ethernet module  
testo 6610 · Probes  
P2A software · Parameterizing, adjusting and analyzing  
software**

**Instruction manual Volume 1**

**en**





# Safety and the environment

## Avoiding electrical hazards

- ▶ Never use the instrument and connected probes to measure on or near live parts!
- ▶ Damaged mains cables must only be replaced by authorized personnel.
- ▶ Only have the transmitter wired and connected by authorized personnel with the voltage disconnected.
- ▶ You must always comply with the regulations applicable in your country to the opening and repair of electrical equipment.

## Avoiding personal injury/damage to equipment

- ▶ Installation, setting and calibration work must only be carried out by qualified and authorized personnel!
- ▶ Only open the instrument when this is expressly described in the instruction manual for installation, maintenance or repair purposes.
- ▶ Observe the permissible storage, transport and operating temperatures.
- ▶ Never store or operate the product with solvents and do not use any desiccants.
- ▶ Do not use the instrument for control purposes at the same time as operating or servicing the transmitter.
- ▶ Only operate the product properly, for its intended purpose and within the parameters specified in the technical data. Do not use force.
- ▶ Carry out only the maintenance and repair work that is described in the documentation. Follow the prescribed steps when doing so. Use only OEM spare parts from Testo.

Any additional work must only be carried out by authorized personnel. Otherwise Testo will not accept any responsibility for the proper functioning of the instrument after repair and for the validity of certifications.

## Protecting the environment

- ▶ Send the product back to Testo at the end of its useful life. We will ensure that it is disposed of in an environmentally friendly manner.

# About this document

- ▶ Please read this documentation through carefully and familiarize yourself with the product before putting it to use. Keep this document to hand so that you can refer to it when necessary. Hand this documentation on to any subsequent users of the product.
- ▶ The following conventions are followed in this document:

**Character/  
display:**

**Explanation/example**



With the signal word **Warning!**:

Warns against hazards which could result in serious physical injury if the precautionary measures indicated are not taken, e.g.:

De-energize the mains connection before connecting the transmitter!



With the signal word **Caution!**:

Warns against hazards which could result in minor physical injury or damage to equipment if the precautionary measures indicated are not taken, e.g.:

Observe the permissible operating temperature!



Important information, e.g.:

Administrator rights are required to install the program under Windows®7, 8 and 10.



Aim of action, e.g.:

➤ **Assembling the instrument at the process connection:**



Requirement that must be met, e.g.:

✓ USB drivers are installed.

Character/ display:	Explanation/example
1	<p>Steps are numbered if a certain sequence of actions must be followed, e.g.:</p> <ol style="list-style-type: none"> <li>1 Loosen and remove housing screws.</li> <li>2 Remove the upper part of housing.</li> </ol>
▪	<p>A step is not numbered if there are no further steps or if the step is optional, e.g.:</p> <p style="padding-left: 40px;">Insert probe connector into socket of testo 6681 until it engages.</p>
" to "	<p>Example entries are in inverted commas, e.g.:</p> <p>The value "0" results in ....</p>
<b>Bold type</b>	<p>Elements of the program interface or instrument display, e.g.:</p> <p>The instrument designation appears in the <b>instrument/parameter file list</b>.</p> <p>Select <b>Main Menu Channel 1</b> and confirm with SET.</p>
...>...	<p>Functions/paths within a menu, e.g.:</p> <p><b>Start &gt; All Programmes &gt; Testo &gt; P2A Software.</b></p>
[ ]	<p>Buttons which start an action, e.g.:</p> <p>Confirm the software key with <b>[OK]</b>.</p>
CAPITAL LETTERS	<p>Keys on the instrument or keypad, e.g.:</p> <p>Press ESC.</p>

# Contents

<b>SAFETY AND THE ENVIRONMENT .....</b>	<b>3</b>
<b>ABOUT THIS DOCUMENT .....</b>	<b>4</b>
<b>CONTENTS.....</b>	<b>6</b>
<b>1 TRANSMITTER.....</b>	<b>8</b>
1.1 Specifications.....	8
1.1.1 Functions and use.....	8
1.1.2 Scope of delivery .....	8
1.1.3 Accessories.....	9
1.1.4 Technical Data .....	9
1.1.5 Dimensions .....	11
1.2 Product description .....	12
1.2.1 At a glance .....	12
1.2.2 Usable probes .....	13
1.2.3 Display and keypad.....	14
1.2.4 Service interface .....	14
1.2.5 Relay board (option) .....	14
1.2.6 Analog outputs .....	15
1.2.7 Parameters.....	15
1.2.8 Scaling .....	16
1.2.9 Alarm handling .....	18
1.3 Commissioning .....	19
1.3.1 Insert Ethernet module (Order no. 0554 6656).....	19
1.3.2 Assembling the instrument.....	21
1.3.3 Connecting the instrument .....	24
1.3.4 Ethernet communication .....	38
1.3.5 Adjusting the instrument .....	57
1.4 Operation .....	67
1.4.1 Relationship between user menu and mini-DIN socket is active .....	67
1.4.2 Key cover .....	68
1.4.3 Password protection .....	69
1.4.4 Structure of user menu .....	69
1.4.5 Overview of the testo 6681 user menu.....	71
1.4.6 The individual main menus .....	73
1.5 Status, warning and error messages.....	86
1.5.1 Status messages .....	86
1.5.2 Warning messages .....	87

1.5.3	Transmitter error messages .....	89
1.5.4	Status codes in cyclical service .....	90
1.5.5	Handling alarm messages .....	90
1.5.6	Namur fault conditions .....	92
1.6	Maintenance and cleaning.....	93
1.6.1	Maintaining the instrument.....	93
1.6.2	Cleaning the instrument .....	93

# 1 Transmitter

## 1.1 Specifications

### 1.1.1 Functions and use

The testo 6681 humidity transmitter with Ethernet module is used in conjunction with plug-in, adjusted probes from the testo 6610 range.



Please refer to *volume 2, chapter 2* for information about commissioning, operating and maintaining the testo 6610 probe.

The testo 6681 humidity transmitter is suitable for the following applications with Ethernet networking, for example:

- Process instrumentation
- Clean rooms
- Test benches
- Drying processes
- Production and storage air quality
- Complex room climate applications.

In addition to the signal transmission of the readings to a control unit via analog outputs, the measurement data can simultaneously be recorded, documented and visualized via Ethernet. Furthermore, it is possible to issue an alarm for those responsible for the process, if necessary.

### 1.1.2 Scope of delivery

The scope of delivery of the testo 6681 humidity transmitter includes the following:

- Key cover
- Rear panel bracket
- Ethernet module



## 1.1.3 Accessories

The following accessories are available for the testo 6681 humidity transmitter:

- Protection caps for probes
- Mains unit
- P2A software (parameterizing, adjusting and analyzing software)
- Assembly accessories.



Information about accessories and their order numbers can be found in *volume 2, chapter 4.2* or on the website at [www.testo.com](http://www.testo.com).

## 1.1.4 Technical Data

### Parameters

- Humidity (various variables and units)
- Temperature (°C/°F)

### Measuring range

- Depends on probe

### Accuracy

- Depends on probe

### Resolution

- 0.1 % RH or 0.1 °C/0.1 °F

### Meas. cycle

- 1/s

### Interface

- Mini-DIN for P2A software (parameterizing and adjusting software)

### Voltage supply

- 4-wire (separate signal and supply lines):  
20 - 30 V AC/DC,  
300 mA power consumption

### Maximum load

- 4-wire: 500 Ω (power output)

### Analogue output\*

- 0 to 1 V ± 1.5 mV (4-wire) or

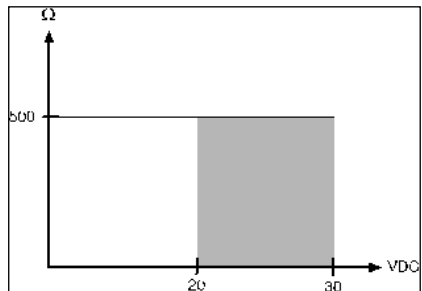

- 0 to 5 V ± 7.5 mV (4-wire) or
- 0 to 10 V ± 15 mV (4-wire) or
- 0 to 20 mA ± 0.03 mA (4-wire) or
- 4 to 20 mA ± 0.03 mA (4-wire)

### Resolution of analog output

- 12 bit

### Relay

- 4 relays, 250 V AC/DC, 3 A (optional)

### Display

- 2-line LCD with plain text line (optional)

### **Housing operating temperature**

---

- -40 to +70 °C/-40 to +158 °F, with display from 0 to 50 °C/+32 to +122 °F
- With integrated relay: -40 - +60 °C

### **Operating humidity**

---

- 0...100 %rF

### **Storage temperature**

---

- -40 to 80 °C/-40 to +176 °F

### **Housing, weight**

---

- Metal: 1.960 kg
- Ethernet module: 0.610 kg

### **Protection class**

---

- IP 65 only if the transmitter is wired properly (closed cable entries), Ethernet connector, Harting PushPull connector and humidity probe are inserted and/or sealing plug is inserted.

### **Directives, standards and tests**

---

- EC Directive: 2014/30/EC
- DIN 14644-4

### **Ethernet module**

---

- Interface:
  - 1 x mini DIN
  - 1 x RJ45 (Ethernet 10 BatesT/100 BaseTX)
- LED:
  - 2 x green

## 1.1.5 Dimensions

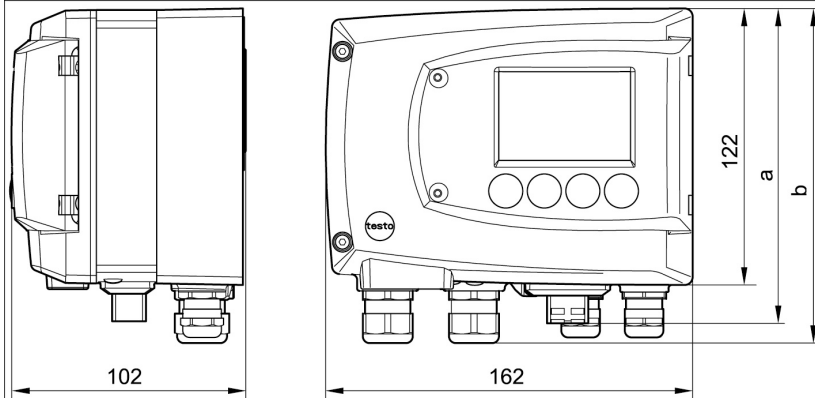

Dimensions in mm	a	b
With M 20 cable couplings	144	147
With NPT cable couplings	144	144
With M plug-in connections	143	

# 1.2 Product description

## 1.2.1 At a glance

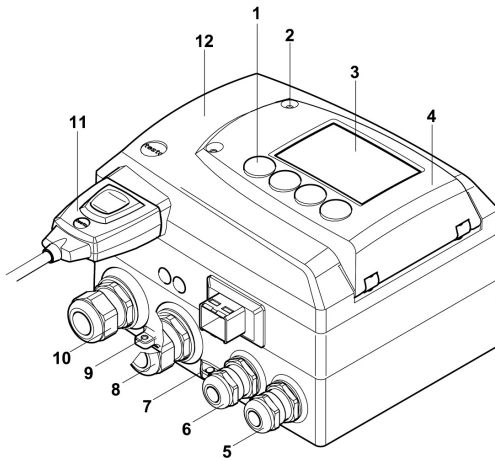

- 1 Keys (with optional display)
- 2 Service flap screw connection (self-locking, 2x)
- 3 Display (optional)
- 4 Service flap
- 5 M 16 x 1.5 screw connection\*, e.g. analog outputs
- 6 M 16 x 1.5 screw connection\*, e.g. voltage supply
- 7 Eyelet for measuring point panel
- 8 M 20 x 1.5 screw connection\*, e.g. relay R 3 and R 4
- 9 Earthing/PE connection
- 10 M 20 x 1.5 screw connection\*, e.g. relay R 1 and R 2
- 11 Probe connector (testo 6610)
- 12 Upper part of housing

\* Alternatively, NPT cable couplings or M plug-in connections are available

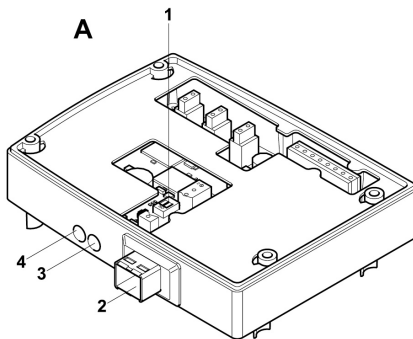

- A Ethernet module
- 13 DIP switch
- 14 Ethernet port
- 15 LED: LAN connection status
- 16 LED: Supply

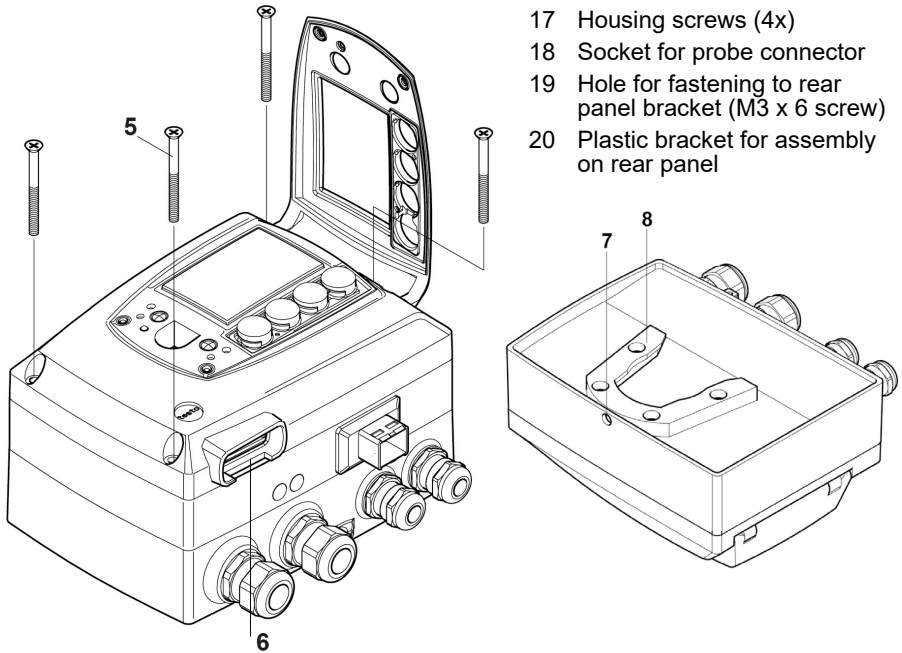

## 1.2.2 Usable probes

The testo 6681 humidity transmitter can be used with the following probes:

Probe	Article no.	Characteristic
testo 6611	0555 6610-L11	<b>Wall</b> probe version; accuracy to $\pm 1\%$ RH; temperature range $-20\text{ °C}$ to $+70\text{ °C}$ / $-4$ to $+158\text{ °F}$
testo 6612	0555 6610-L12	<b>Duct</b> probe version; accuracy to $\pm 1\%$ RH; temperature range $-30\text{ °C}$ to $150\text{ °C}$ / $-22$ to $+302\text{ °F}$
testo 6613	0555 6610-L13	<b>Cable</b> probe version; accuracy to $\pm 1\%$ RH; temperature range $-70\text{ °C}$ to $+180\text{ °C}$ / $-94$ to $+356\text{ °F}$
testo 6614	0555 6610-L14	<b>Heated cable</b> probe version; accuracy to $\pm 1.0\%$ RH; temperature range $-40\text{ °C}$ to $+180\text{ °C}$ / $-40$ to $+356\text{ °F}$
testo 6615	0555 6610-L15	<b>Trace humidity cable</b> probe version; dew point to $-60\text{ °C}$ td temperature range $-40\text{ °C}$ to $+120\text{ °C}$ / $-40$ to $+248\text{ °F}$
testo 6617	0555 6610-L17	<b>Cable with cover electrode monitoring</b> probe version; accuracy to $\pm 1.2\%$ RH; temperature range $-40\text{ °C}$ to $+180\text{ °C}$ / $-40$ to $+356\text{ °F}$

### 1.2.3 Display and keypad

The display option allows the testo 6681 humidity transmitter to be operated via the display and four keys.

The LCD display consists of two 7-segment lines for displaying readings and units and of an information line (for status messages, for example).

The brightness and contrast of the display and the background lighting (permanent or off) can be changed via the user menu or the P2A software.

### 1.2.4 Service interface

Behind the service flap is the parameterizing socket (mini-DIN) as an interface to the P2A software.

### 1.2.5 Relay board (option)

This has a floating switch capacity of 250 V AC/3 A. The switching limits and hysteresis can be set via the display or the P2A software. Further features include:

- Function of changeover contacts (NC/NO contacts) freely selectable
- 12 terminals for a total of 4 relays.



If no relays are available, settings for monitoring limit values or alarms can still be controlled via the display. The alarm status will be shown on the display.



Only have the transmitter wired and connected by authorized personnel with the voltage disconnected.

## 1.2.6 Analog outputs

For analog outputs, the testo 6681 has either

- 2 or optionally 3 current outputs of 4 to 20 mA/0 to 20 mA (4-wire) or
- 2 or optionally 3 voltage outputs of 0 to 1 V/0 to 5 V/0 to 10 V (4-wire).

The transmitter can be ordered with a third analog output as an option.

## 1.2.7 Parameters

The following parameters are displayed:

- Relative humidity in %RH (technical)
- Relative humidity in % WMO\* (calculation according to the WMO standard)
- Temperature °C and °F
- Dewpoint in °Ctd and °Ftd
- Absolute humidity in g/m<sup>3</sup> and gr/ft<sup>3</sup>
- Degree of humidity in g/kg and gr/lb
- Enthalpy in kJ/kg and BTU/lb
- Psychrometer temperature in °Ctw and °Ftw
- Water vapour partial pressure in hPa and "H<sub>2</sub>O (inch H<sub>2</sub>O)
- Water content in ppmvol and % vol
- Dewpoint of H<sub>2</sub>O<sub>2</sub> mixture in °Ctm and °Ftm
- Mixture humidity H<sub>2</sub>O<sub>2</sub> in %RH<sub>m</sub>

\*It is possible that condensation appears as of a displayed humidity starting from 70 % and is shown on the display. This unit is used in meteorology, for example. According to the WMO, the Magnus coefficient is used for sub-cooled water in the calculation of relative humidity.



Calculated humidity variables correspond to the medium of air. With other gases/gas compositions, deviations may occur, e.g. with the enthalpy

## 1.2.8 Scaling

There are three types of min./max. values:

### 1 The measuring range

The maximum sensor performance is in this range. Values outside of the measuring range are displayed via messages, for example. Refer to table (see below) for the measuring range.

### 2 Standard scaling

The output signals are assigned to this measuring range as standard:

- during delivery if no entries are made in the order code
- after exchanging the unit, the measuring range recorded in the instrument is applied as standard.



The transmitter even retains its scaling with the voltage disconnected.

Refer to table (see below) for the measuring range.

### 3 The maximum settings for the manual scaling

- the values are not expressly given in the table. The maximum limits can be calculated as follows:

X = difference between MIN. and MAX. value of the standard scaling

(Max. value of standard) + (50 % of X)

(Min. value of standard) - (50 % of X)

- It is thus possible to scale beyond the measuring range, e.g. for the adjustment of the scaling limits to standard values of a PLC.

However, the physical measurement range limits are the deciding factor when defining alarms.



Parameter	Unit	Probe	Measuring range Physical at 1013 hPa		Standard scaling MUF measuring range	
			MIN	MAX	MIN	MAX
			Temperature	°C	6611	-20
	°F	6611	-4	+158	-4	+158
	°C	6612	-30	+150	-30	+150
	°F	6612	-22	+302	-22	+302
	°C	6613	-70	+180	-40	+180
	°F	6613	-94	+356	-40	+356
	°C	6614, 6617	-40	+180	-40	+180
	°F	6614, 6617	-40	+356	-40	+356
	°C	6615	-40	+120	-40	+120
	°F	6615	-40	+248	-40	+248
relative humidity	% RH		0	+100	0	+100
WMO relative humidity	% RH		0	+100	0	+100
Mixture humidity H <sub>2</sub> O <sub>2</sub>	% RH <sub>m</sub>		0	100	0	100
Dewpoint	°C <sub>td</sub>	6611	-20	+70	-80	+100
	°F <sub>td</sub>	6611	-4	+158	-112	+212
	°C <sub>td</sub>	6612, 6613, 6614, 6617	-20	+100	-80	+100
	°F <sub>td</sub>	6612, 6613, 6614, 6617	-112	+212	-112	+212
	°C <sub>td</sub>	6615	-60	+30	-80	+100
	°F <sub>td</sub>	6615	-148	+212	-112	+212
Mixture dewpoint (H <sub>2</sub> O <sub>2</sub> )	°C <sub>tm</sub>		-20	+100	-20	+100
	°F <sub>tm</sub>		-4	+212	-4	+212
Absolute humidity	g/m <sup>3</sup>	all probes	0	600	0	2000
	gr/ft <sup>3</sup>		0	250	0	800
Degree of humidity	g/kg	all probes	0	13300	0	9500
	gr/lb		0	93000	0	66500
Enthalpy	kJ/kg		-40	99999	-40	8000
	BTU/lb		-18	43000	-18	3500
Psychrometer temperature	°C <sub>tw</sub>		-40	100	-40	180
	°F <sub>tw</sub>		-58	210	-40	356

Parameter	Unit	Probe	Measuring range Physical at 1013 hPa		Standard scaling MUF measuring range	
			MIN	MAX	MIN	MAX
			Water content	ppm vol H2O		0
	% vol		0	100	0	100
Water vapour partial pressure	hPa		0	1000	0	7000
	inchH2O		0	400	0	2800

## 1.2.9 Alarm handling

For upper and lower alarm limits, individual alarms as well as collective alarms can be specified. If the collective alarm function is activated, an alarm is triggered as soon as the alarm limit of an alarm is exceeded, if this alarm is assigned to the collective alarm.

The testo 6681 monitors limit values using relays. If a reading is outside the limit values, a relay to be specified by the user is switched.

If the reading reverts to more than a specified hysteresis below or above the limit value, the alarm is cancelled.

In addition, information about the occurrence of error/status messages can be provided by means of a collective alarm relay, see *chapter 1.5, Status, warning and error messages*.



If multiple alarm messages are activated at the same time, the last alarm is shown. If the alarm is cancelled again, the previous messages are no longer shown.



Example:

If the condensation of the probe begins, the "Condensation" message appears on the display and the "Start" status display. If the condensation is over, the status display changes from "Start" to "End".

## 1.3 Commissioning

### 1.3.1 Insert Ethernet module (Order no. 0554 6656)

The Ethernet module can be ordered retroactively as an accessory. It can easily be installed in the testo 6681 humidity transmitter.

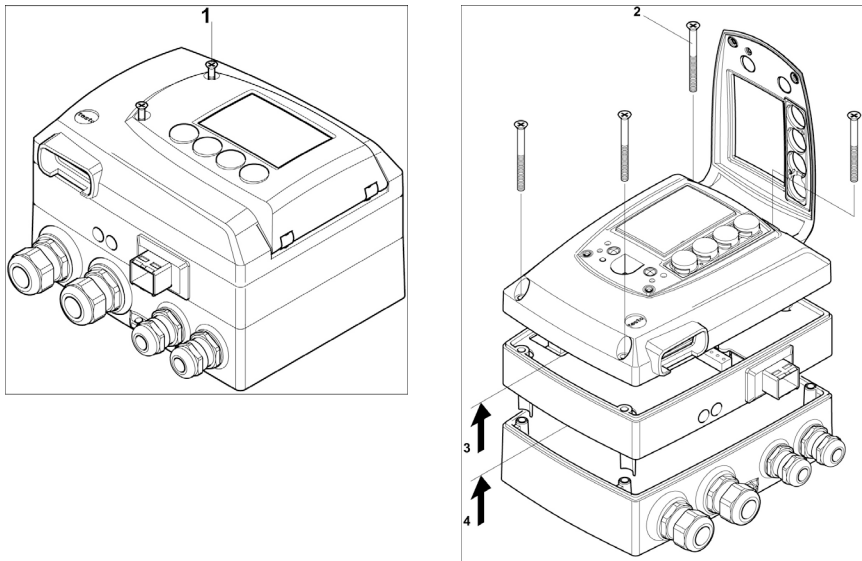

- ✓ The probe connector must be disconnected.
- 1 Loosen screw connection **(1)** of service flap and open the flap.
- 2 Loosen and remove housing screws **(2)**.
- 3 Remove upper part of housing **(3)** and place on a clean surface.

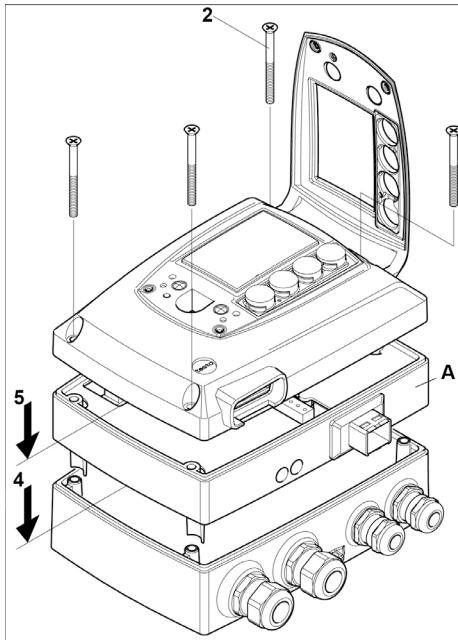

- 4 Place Ethernet module **(A)** on lower part of instrument **(4)**.



If necessary, manually set the address using the rotary encoder switches (see *chapter 1.3.3.6* before fixing the instrument in place.

- 5 Set on upper part of instrument **(5)** and fix in place using housing screws **(2)**.

## 1.3.2 Assembling the instrument

### 1.3.2.1 Wall mounting (for testo 6611/6613/6614/6615/6617 probes)

➤ Attaching rear panel bracket

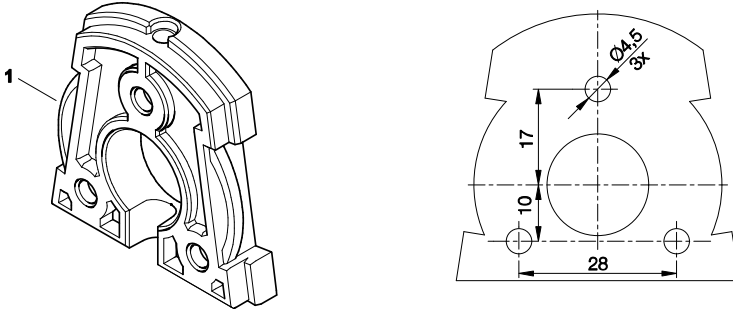

- 1 Remove locking screw (item **(4)** of drawing on page 21) and detach rear panel bracket from plastic bracket (item **(2)** of drawing on page 21).
- 2 Hold rear panel bracket in assembly position and mark the three drill holes.
- 3 Drill three holes ( $\varnothing 5$  mm) and insert dowels where necessary.
- 4 Screw on rear panel bracket.  
Remember that the clamping brackets **(1)** must face the wall.

➤ **Fastening instrument to rear panel bracket**

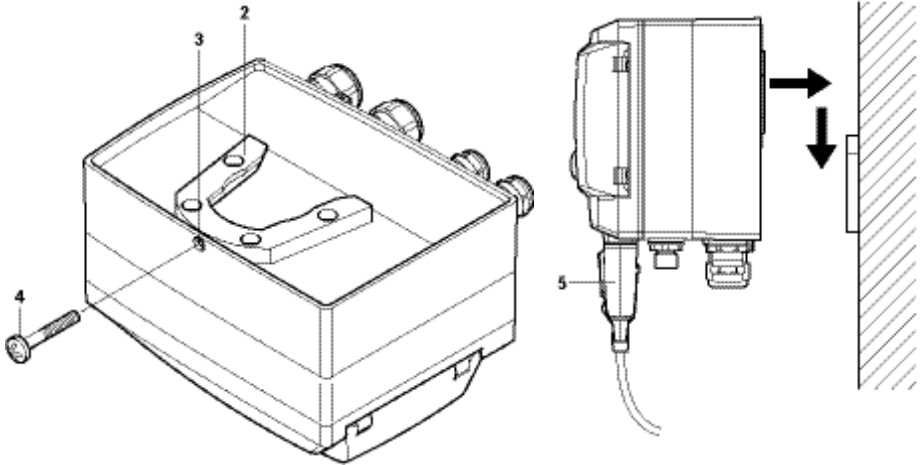

- 1 Slide plastic bracket (2) on the back of instrument onto rear panel bracket until it engages (see arrows).
- 2 Insert screw (4) through hole (3) and screw into rear panel bracket.
- 3 Insert probe connector (5) into socket until it engages.

### 1.3.2.2 Duct mounting (for testo 6612 probes)

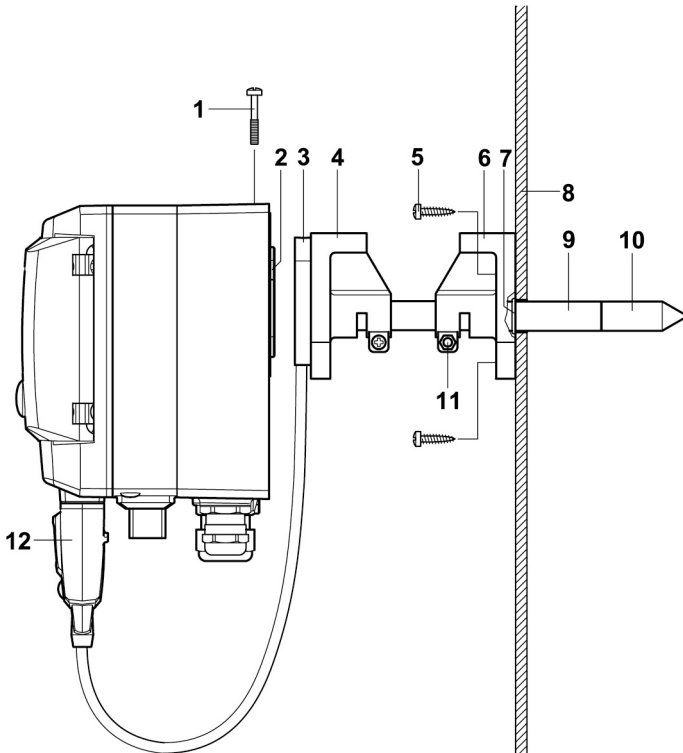

- 1 Hold wall/duct bracket (order no. 0554 6651) **(6)** against duct wall **(8)** and mark drill holes for wall/duct bracket and probe shaft.
- 2 Drill a hole ( $\varnothing$  12,5 mm) in the duct wall to feed through the probe shaft.
- 3 Fasten wall/duct bracket **(6)** to duct wall with screws **(5)**.
- 4 Push probe shaft **(9)** with filter **(10)** through the middle hole of the mounting bracket.



The wall/duct bracket **(6)** has an O-ring **(7)** to seal it against the duct. Feed the probe shaft **(9)** carefully through the wall/duct bracket so that the O-ring is not damaged.

- 5 Fix the correct position of the probe shaft **(9)** with screw **(11)** and mark (insert probe shaft as far as possible).

- Slide plastic bracket **(2)** on the back of the transmitter onto bracket **(3, 4)** until it engages.



Take the weight of the transmitter into account. Ensure that the brackets **(4, 6)** are fastened securely.

- Insert screw **(1)** through hole on the top of the instrument and screw into bracket **(3)**.
- Insert probe connector **(12)** into socket until it engages.

### 1.3.3 Connecting the instrument

#### ➤ Opening the instrument

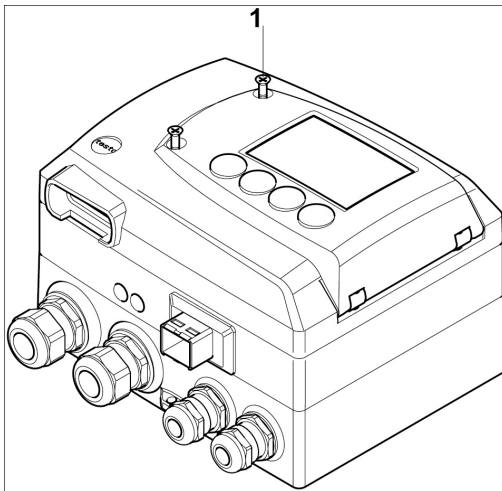

- Loosen screw connection **(1)** of service flap and open the flap.



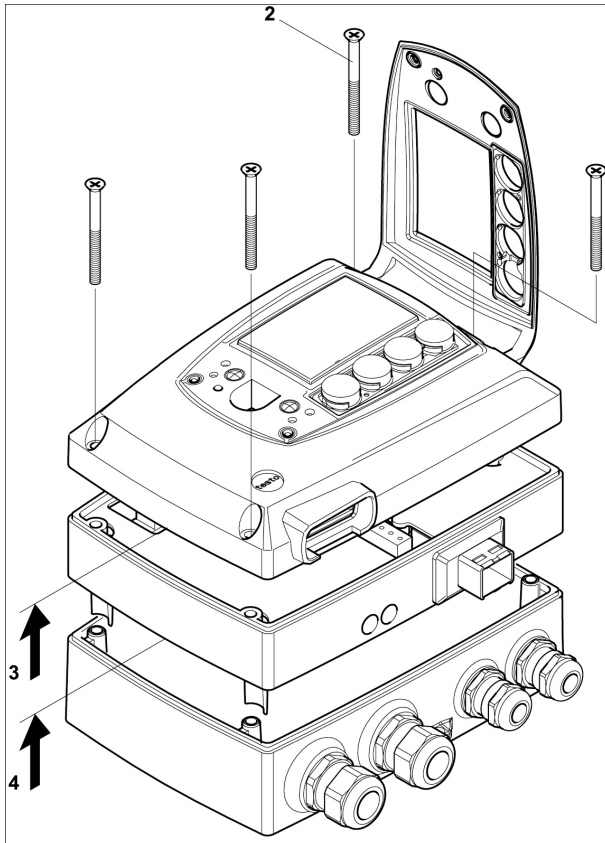

- 2 Loosen and remove housing screws (2).



Important.

The Ethernet module (A) is already separated from the upper and lower parts of the instrument when the housing screws (2) are removed.

- 3 Remove upper part of housing (3) and place on a clean surface.
- 4 Remove Ethernet module (A) from lower part of housing (4) and also place on a clean surface.



**Warning!**

Electrical voltage.

Danger of short-circuit!

De-energize the mains connection before connecting the transmitter!



Only have the transmitter wired and connected by authorized personnel with the voltage disconnected.

**1.3.3.1 Overview of terminals**

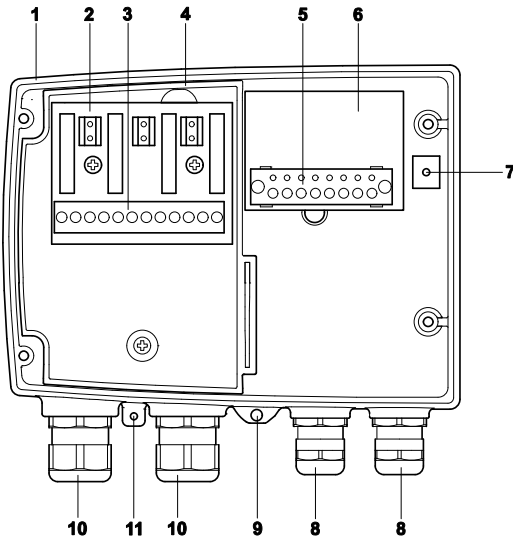

- 1 Lower part of housing
- 2 Relay board (option)
- 3 Relay terminals
- 4 Insulating trough for relay board
- 5 Terminal strip for voltage supply and analog outputs\*
- 6 Terminal board
- 7 Earthing terminal (internal)

- 8 M 16 x 1.5 screw connection\*\*
- 9 Earthing terminal (external)
- 10 M 20 x 1.5 screw connection\*
- 11 Eyelet for measuring point panel

\*\* Alternatively, NPT cable coupling or M plug-in connection.



The following description of the terminals refer to this overview and its numbering.

### 1.3.3.2 Connecting voltage supply and analog outputs

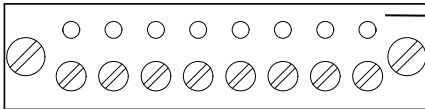

Terminal strip for voltage supply and analog outputs (item **(5)** of **Overview of terminals**, chapter 1.3.3.1).

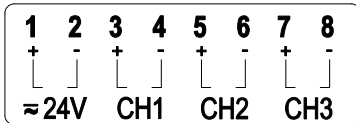

- 1 Feed cable with voltage supply and analog signal lines through opened M 16 x 1.5 screw connection (item **(8)** in Overview of terminals, *chapter 1.3.3.1*).
- 2 Strip the cable ends, clamp wire end ferrules on and screw down onto voltage terminals.
- 3 Close M 16 x 1.5 screw connection (item **(8)** in Overview of terminals, *chapter 1.3.3.1*).

**Wiring diagram for 4-wire system  
(0 to 20 mA/4 to 20 mA/0 to 1 V/0 to 5 V/0 to 10 V)**

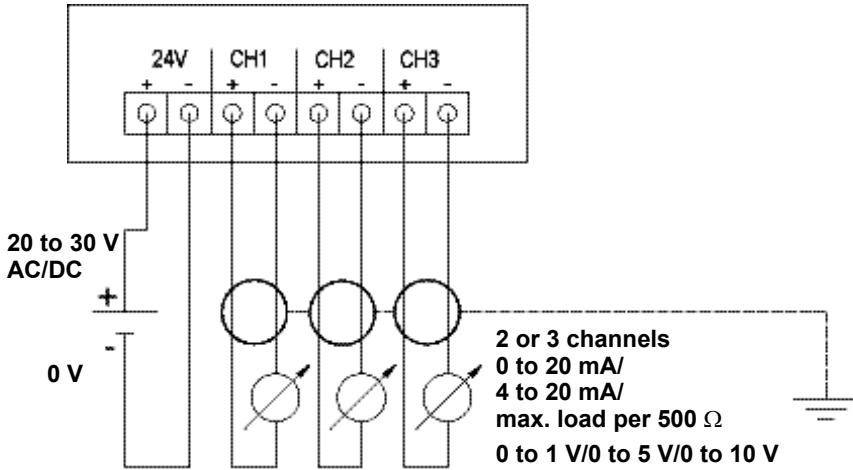

Requirement for the connecting cable of the supply:

- Insulated with cross-section of at least 0.25 sq. mm.
- The supply line must be secured against exceeding 8 A.
- An OFF switch must be installed in an easily accessible position close by and be marked as such.

- 1 Feed connection cables of the two, or optionally three, channels through opened M 16 x 1.5 screw connection (item **(8)** in *Overview of terminals, chapter 1.3.3.1*.
- 2 Strip the cable ends, clamp wire end ferrules on and screw to channel terminals as shown in diagram.
- 3 Close M 16 x 1.5 screw connection (item **(8)** in *Overview of terminals, chapter 1.3.3.1*.

### 1.3.3.3 Connecting the relay outputs



Only have the transmitter wired and connected by authorized personnel with the voltage disconnected.

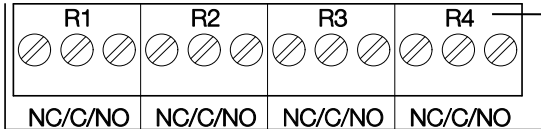

Relay terminal strip (item **(3)** of *Overview of terminals*, chapter 1.3.3.1.

There is the option of twelve terminals for a total of four relays. The designations NC/C/NO (normally closed contact/root or pin/normally open contact) are etched on the surface of the board.

#### Using M screw connection

- 4 Feed connection cables for the relays through opened M 20 x 1.5 screw connection (item **(10)** of *Overview of terminals*, chapter 1.3.3.1.
- 5 Strip cable ends and clamp on wire end ferrules.
- 6 Connect relays according to chosen function (NC/NO) (see diagrams below; relay 1 is shown as an example of a connection).

#### Using plug-in connections (optional)



Only insert or disconnect the plug-in connection when the voltage is disconnected.

- 1 Clean the connector of the probe line and the coupling of any foreign matter.



Do not disconnect the connector of the probe line from the instrument for extended periods to protect against contamination.

### Connection note

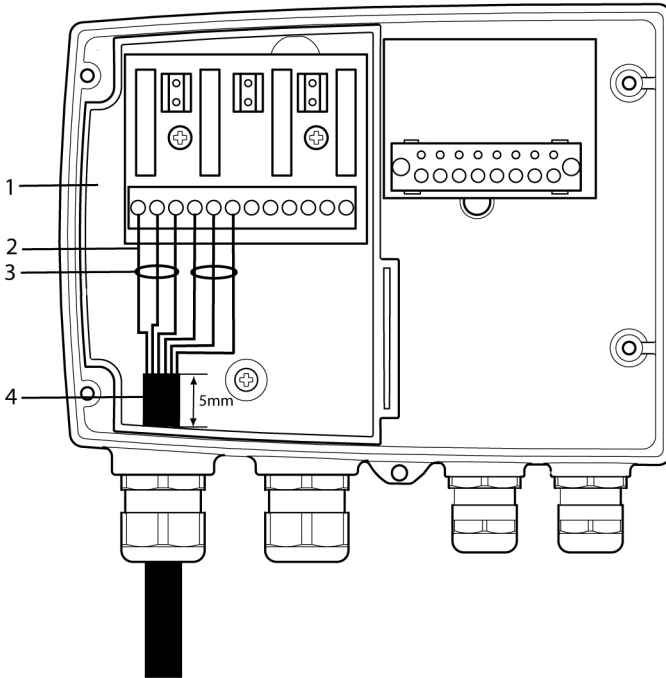

- For the connection, a double-insulated mains cable (sheathed cable) with a cross-section of at least 1.5 sq. mm must be used.
- Cable connection (2) may not be routed in a loop within the tray (1).
- In order to protect from electrical shock if the wire severs or falls out, 3 wires must always be bound together with a cable tie (3).
- The insulation of the cable must be fed at least 5 mm (4) into the tray.

**Use of relay as NC contact (NC = normally closed)**

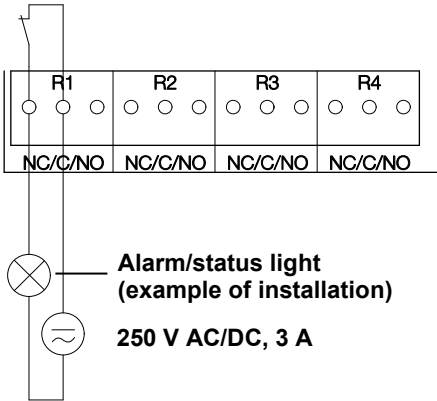

The busy light (alarm/status light) is permanently on until the relay opens or the circuit is interrupted. This circuit can therefore be used to monitor the functionality of the alarm circuit, as a cable break, for instance, is indicated by the busy light going off.

**Use of relay as NO contact (NO = normally open)**

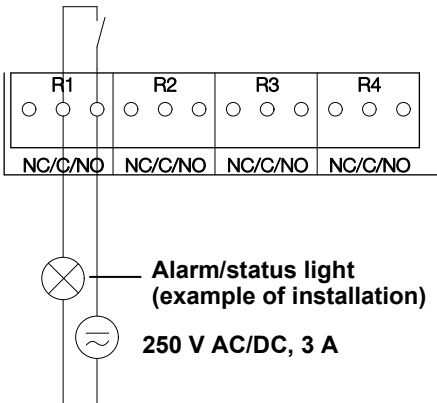



The busy light (alarm/status light) only comes on when the relay is switched (closed). Monitoring the functionality of the alarm circuit is therefore not possible with this switching operation.

- 2 Close M 20 x 1.5 screw connection (item **(10)** in *Overview of terminals, chapter 1.3.3.1.*

### 1.3.3.4 Plug-in connection option

As an option, the M screw connections of the signal and supply lines can be replaced with plug-in connections that are installed at the housing (see Fig. 1 and 2). The relay cabling occurs via standard cable entries and PG screw connections, see Fig. 3 and 4

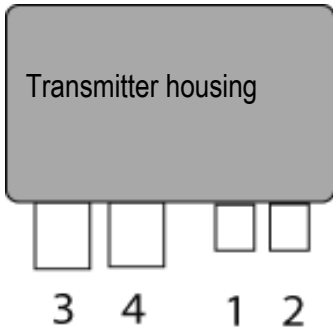

Plug-in connections for power supply and channels  
 M12 plug-in connection (5-pin) socket (1)

View of the plug-in connections in the installed state from outside.

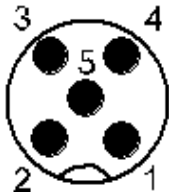

Pin	Assignment.
1	V 24 -
2	V 24 +
3	+ Ch 1
4	- Ch 1
5	PE



M12 plug-in connection (5-pin) connector (2)

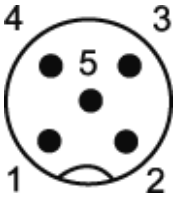

Pin	Assignment.
1	- Ch 2
2	+ Ch 2
3	+ Ch 3
4	- Ch 3
5	PE

### 1.3.3.5 Creating the PE/earthing terminal

As the testo 6681 has a metal housing, we recommend that the instrument be earthed. This can be done using the earthing terminal within the instrument (1) or the earthing terminal outside of the instrument (2).



Only use the external earthing terminal in dry interiors.

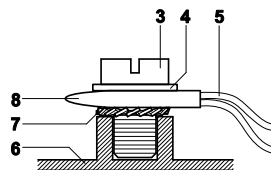
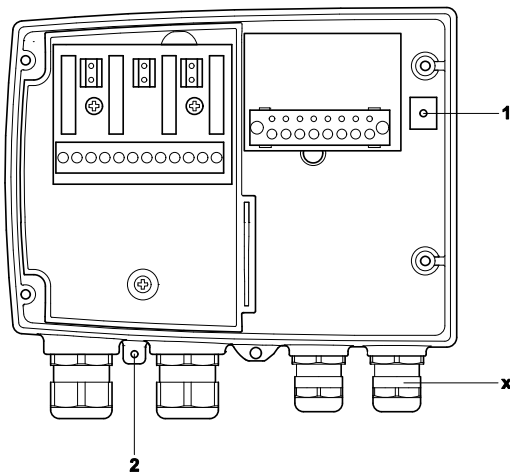

### Using the earthing terminal within the instrument

- 1 Guide PE line (yellow-green) **(5)** through the cable coupling **(x)** and fit cable lug **(8)**. Fix this to the side of the instrument **(6)** using M 5 screw **(3)**, washer **(4)** and snap ring **(7)** on the internal earthing terminal **(1)**.
- 2 Place the other cable end on an appropriate (PE) earth conductor, e.g. an earthing bar.

### Using an earthing terminal outside of the instrument

- 1 Use shielded cable **(5)** with cable lug **(8)**. Fix this in place using M 5 screw **(3)**, washer **(4)** and snap ring **(7)** on the external earthing terminal **(2)**.
- 2 Place the other cable end on an appropriate (PE) earth conductor, e.g. an earthing bar.

### 1.3.3.6 Setting the Ethernet module

Using a DIP switch the Ethernet module can be switched between two main functions:

- Saveris subscriber function (DIP switch No 1 = on)  
testo 6681 is used as a testo Saveris component.
- XML server function (DIP switch No. 1 = off)  
integration of the testo 6681 into the customer's Ethernet system.



Important:

On delivery, the testo 6681 with Ethernet module is in Saveris mode (switch setting "on").

- ✓ The testo 6681 must be disconnected from the Ethernet network.

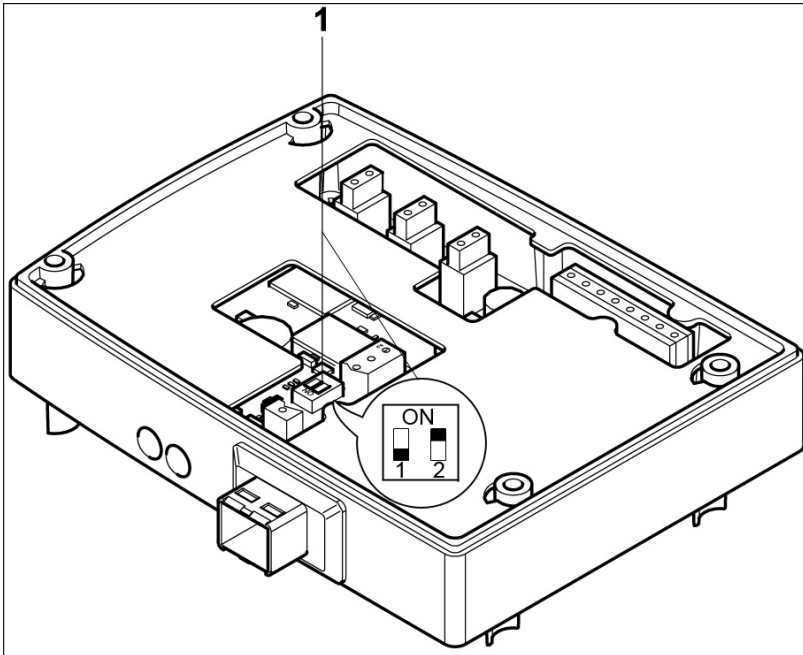

- 1 Open transmitter (see Section *Connecting the instrument, chapter 1.3.3*).
- 2 Set the DIP switch no. 1 (**1**) on the Ethernet module.  
In the illustration: DIP switch no. 1 off, DIP switch no. 2 on
- 3 Set Ethernet module on lower part of housing (**see arrow**).

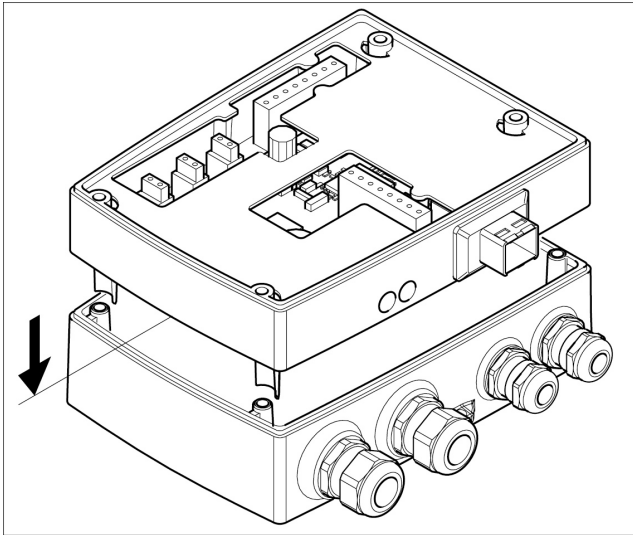

- 4 For the configuration of the Ethernet module, see following chapter.
- 5 If you do not wish to perform a configuration, close the transmitter (see chapter 5).

### 1.3.3.7 Closing the instrument

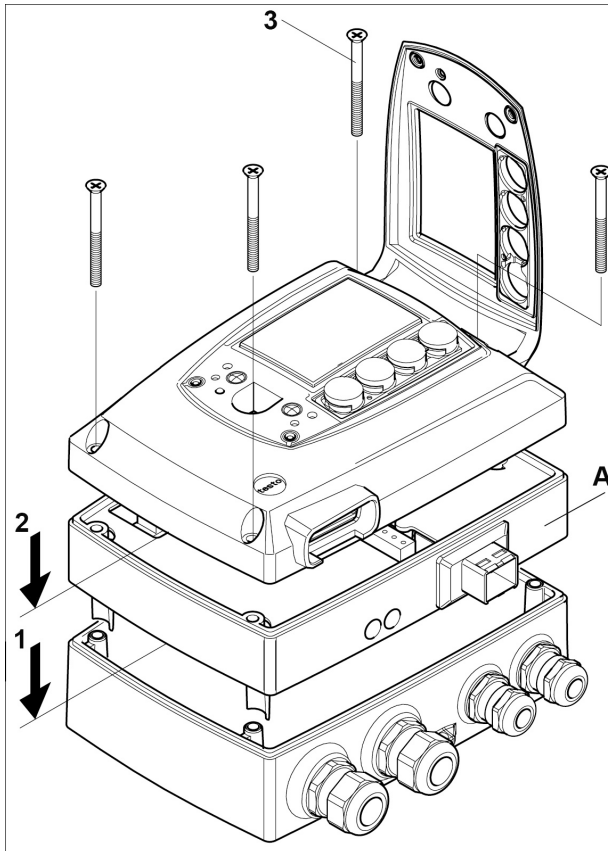

- 1 Place Ethernet module **(A)** on lower part of instrument **(1)**.
- 2 Set on upper part of instrument **(2)** and fix in place using housing screws **(3)**.

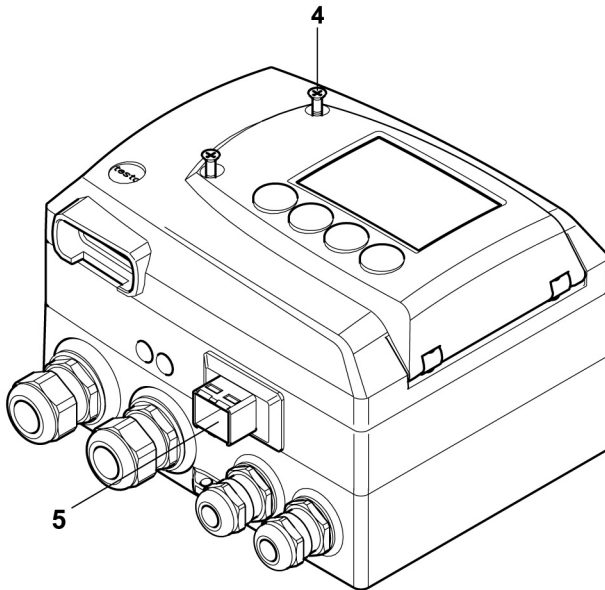

- 3 Close the service flap and tighten screws (4).
- 4 Connect the Ethernet network cable to the transmitter via the Ethernet socket (5).

## 1.3.4 Ethernet communication

### 1.3.4.1 Types of operation

In general, the Ethernet module performs two functions:

- a corresponding testo 6681 becomes a Saveris subscriber
- a corresponding testo 6681 can be integrated into any Ethernet systems

### 1.3.4.2 Network connection

- Connect the Ethernet network cable to the transmitter via the Ethernet socket.



The network cable may not be connected directly to the telephone network (ISDN).

In order to guarantee the IP protection, an RJ 2.5 Harting Push-Pull plug must be used.

### 1.3.4.3 LED status displays

Characteristic	LED 1	LED 2
Colour	green	green
Status display for	Voltage supply	LAN connection
Status: off	No voltage supply	No LAN connection
Status: stays on	Voltage supply present	LAN connection present
Status: flashes		Data transfer

### 1.3.4.4 testo 6681 as Saveris subscriber

#### Set the IP address

- ✓ Network cable must be connected.

The IP address of the transmitter can either be set via the P2A software (transmitter accessories) or via the configuration menu of testo Saveris™ (testo Saveris™ Startup Wizard).

- Set IP address with the P2A software (see Chapter 3.3) or with the testo Saveris™ Startup Wizard (see instruction manual).

#### Using Saveris

- Start Saveris software (see instruction manual **Measurement data monitoring with testo Saveris**)



Ensure that the Saveris software is not already open, for example in multi-user operation under Windows® Vista.

If multiple clients are installed in a network, make sure that no simultaneous changes are made to the system configuration by the clients during simultaneous operation of the clients.

---

#### 1. [Start] | All Programs | Testo |

- **Select Saveris Professional Client** (full version).  
The entry is available if Saveris Professional Client is installed
- **Select Saveris Viewer** (limited functionality).  
The entry is available if Saveris Professional Viewer is installed

- The **Testo Saveris software** program window is opened with the **Select project** dialogue.

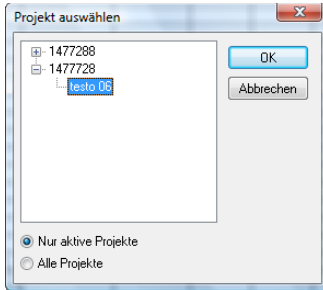

---

**i** If the software will not start, check whether the **testo tdassvcs** service is started in the service management of the operating system and restart it, if needed.

---

2. Select the
    - **Only active projects** option if the data from a running project should be opened
    - **All projects** option if the data from a completed project should be opened.
  3. In the tree structure, select the project that is to be opened.
  4. Confirm with **[OK]**.
- The **Testo Saveris software** program window is shown with the selected data record in the foreground.

### 1.3.4.5 Integration into customer's Ethernet system

#### Precondition



The user should be familiar with the structure of an XML document. Furthermore, enough knowledge should be available that this type of document can be downloaded and decoded via an Internet connection with the aid of a programming/script language



## Interface

The communication takes place according to the client/server principle, whereby the Ethernet module takes on the role of the server:

The XML interface will be approached via a URL. The URL consists of the IP address of the Ethernet module, the path for the XML document and, depending on the URL, with a clearly defined parameter. If a parameter is missing or an incorrect value is transferred, the Ethernet module sends back a simple error message.

Example:

IP address = 254.169.100.100  
URL for serialnumber.xml:  
`http://254.169.100.100/data/getserialnumber`

If a parameter is required, a "?" (question mark) is always in the first place after the URL then the parameter is transferred to the common query string form (name=value).

Example:

IP address = 254.169.100.100  
URL for / identification.xml:  
`http://254.169.100.100/data/getidentification?param=0` (compare table xml codes)

After calling up the compound URL, if everything was correct, an XML document is returned. With faulty parameters a simple HTML answer comes that points out the reason that an XML answer could not be given.

If an XML document is to be loaded on the server, access is provided by means of a POST request

Example of an upload via the program wget:  
IP address = 254.169.100.100  
URL for / deviceident.xml:  
`H:/wget/wget-complete-stable/wget--post-file=C:/usersettings.xml 193.168.1.5/config/setusersettings`

The Ethernet module supports reading out of

- Readings
- Instrument type (testo 6681)
- Firmware date and version (testo 6681)
- Status and status messages (testo 6681)

- Alarm messages (testo 6681)
- Service hour counter (testo 6681 and probe)

as well as the reading and writing of the:

- Adjustment data (testo 6681)
- Configuration data of analog outputs (testo 6681)
- Configuration data of relays (testo 6681)
- User settings (testo 6681)

### XML codes (download)

The table of xml codes is available for download at [www.testo.com/download-center](http://www.testo.com/download-center) (registration required)

URL	Description	Parameter	Answer (see Appendix)
/data/getserialnumber	Read off serial number of connected transmitter		serialnumber.xml
/data/getidentification	Read off type of connected transmitter/ probe	param=0 (for transmitter) param=1 (for probe)	identification.xml
/data/getversion	Read off firmware version of connected transmitter		version.xml
/data/getfirmwaredate	Read off firmware date of connected transmitter		firmwaredate.xml
/data/getonlinevalue	Read off online values of connected transmitter		onlinevalue.xml
/data/getviewchannels	Read off view channels of connected transmitter		viewchannels.xml
/data/getstatus	Read off status of connected transmitter		status.xml
/data/getlaststatusmessage	Read off last status message of connected transmitter		laststatusmessage.xml
/config/gethourscount	Read off service hour counter of transmitter or probe	param=0 (for transmitter) param=1 (for probe)	hourscount.xml
/config/getusersettings	Read off settings of transmitter		usersettings.xml
/config/getcalibration	Read off adjustment data of transmitter	param=0 (adjustment set 1) param=1 (adjustment set 2) param=2 (adjustment set 3)	calibration.xml
/config/getredefinition	Read off relay information of transmitter	param=0 (relay 1) param=1 (relay 2)	redefinition.xml

URL	Description	Parameter	Answer (see Appendix)
		param=2 (relay 3) param=3 (relay 4)	
/config/getheatertime	Read off sensor heating information		heatertime.xml
/config/getoptions	Read off options of transmitter		options.xml
/config/getcollectivealarm	Read off alarm messages of transmitter		collectivealarm.xml

## Upload XML documents

URL	Description	Parameter	Post	Answer (see Appendix)
/config/setusersettings	Perform settings of testo 6681		usersettings	usersettings.xml
/config/setcalibration	Set adjustment data of transmitter	param=0 (adjustment set 1) param=1 (adjustment set 2) param=2 (adjustment set 3)	calibration.xml	calibration.xml
/config/setredefinition	Set relay information of transmitter	param=0 (relay 1) param=1 (relay 2) param=2 (relay 3) param=3 (relay 4)	redefinition.xml	redefinition.xml
/config/setheatertime	Set sensor heating information		heatertime.xml	heatertime.xml
/config/setoptions	Set options of transmitter		options.xml	options.xml
/action/setresetm	Not yet implemented		resetm.xml	

## Description of the XML elements

### General elements

XML tag	Description	Type
measurement_value	Parent element. Contains the child elements value, unit, resolution	
value	Reading	Numerical, decimal number
unit	Unit	ASCII
number_values	Qty.	Numerical, whole number

## Elements in calibration.xml

XML tag	Description	Type
calibration_data	Base element. Contains the child elements unit, attenuation, cal_reserved, cal_offset, cal_scale.	
unit	See general elements	
attenuation	Damping (0 - 15)	Numerical, whole number
cal_offset	Offset	Numerical, decimal number
cal_scale	Parent element. Contains the child elements cal_minscale, cal_maxscale	
cal_minscale	Scaling value	Numerical, decimal number
cal_maxscale	Scaling value	Numerical, decimal number

## Elements in collectivealarm.xml

XML tag	Description	Type
colalarmtable	Base element. Contains the child elements alarm_numbers, alarm	
alarm_numbers	Number of alarm messages	Numerical, whole number
alarm	Parent element. Contains the child elements alarm_event, alarm_state	
alarm_event	Type of alarm	ASCII
alarm_state	Status of the alarm 0 = alarm inactive 1 = alarm active	Numerical, whole number

## Elements in deviceident.xml

XML tag	Description	Type
ident	Base element. Contains the child element device_id	
device_id	ID of transmitter or probe	Numerical, whole number

## Elements in firmwaredate.xml

XML tag	Description	Type
firmware_date	Base element. Contains the child elements year, month, day	
year	Year	Numerical, whole number
month	Month	Numerical, whole number
day	Day	Numerical, whole number

## Elements in heatertime.xml

XML tag	Description	Type
heatertime	Base element. Contains the child element heatertimeoff	
heatertimeoff	Time sensor heating off in min	Numerical, whole number

## Elements in hourscount.xml

XML tag	Description	Type
hourcount	Base element. Contains the child element hours	
hours	Service hour counter in h	Numerical, whole number

## Elements in identification.xml

XML tag	Description	Type
ident	Base element. Contains the child element device_id	
device_id	Transmitter type	Numerical, whole number

## Elements in laststatusmessage.xml

XML tag	Description	Type
mufmsg	Base element. Contains the child elements msg, sn, hours	
msg	Status message	ASCII
sn	Serial number	ASCII, 8 characters
hours	Service hour counter in h	Numerical, whole number

## Elements in onlinevalue.xml

XML tag	Description	Type
online_values	Base element. Contains the child elements number_values, measurement_value	
number_values	See general elements	
measurement_value	See general elements	

## Elements in options.xml

XML tag	Description	Type
options	Base element. Contains the child elements device_options, production_options, country_option, option_counter	
device_options	See device_options description	Numerical, whole number
production_options	See production_options description	Numerical, whole number

## Elements in redefinition.xml

XML tag	Description	Type
relay_data	Base element. Contains the child elements relay_channel,	

	relay_number, relay_status, sw_point_character, sw_point_value, hysteresis_value	
relay_channel	Measurement channel linked to the relay	Numerical, whole number
relay_number	Relay number (0 - 2)	Numerical, whole number
relay_status	Status of relay 0 = off 1 = on	Numerical, whole number
sw_point_charact	Switch point: Switch point: 0 = low-limit monitoring 1 = high-limit monitoring	Numerical, whole number
sw_point_value	Switch point	Numerical, decimal number
hysteresis_value	Hysteresis	Numerical, decimal number

Elements in serialnumber.xml

XML tag	Description	Type
serialnumber	Base element. Contains the child element number	
number	Serial number	ASCII, 8 characters

Elements in status.xml

XML tag	Description	Type
mufstatus	Base element. Contains the child elements statemsg, staterel, statecounter	
statemsg	Status message See statemsg description	Numerical, whole number
staterel	Status relay See staterel description	Numerical, whole number
statecounter	Counter	Numerical, whole number

## Elements in usersettings.xml

XML tag	Description	Type
usersettings	Base element. Contains the child elements pressure, h2o2, setting_display, backlight, contrast, language, disp_msg, h2o2_prozess	
pressure	Absolute pressure	Numerical, decimal number
h2o2	H2O2 value	Numerical, decimal number
setting_display	Auto OFF background lighting 0 -> background lighting auto OFF 1 -> background lighting stays on	Numerical, whole number
backlight	Brightness of background lighting 0 - 9 (0 = off, 9 = max.)	Numerical, whole number
contrast	Display contrast 0 - 9 (0 = min., 9 = max.)	Numerical, whole number
language	Language 0 ->GERMAN 1 ->ENGLISH 2 ->FRENCH 3 ->SPANISH 4 ->ITALIAN 5 ->JAPANESE	Numerical, whole number
disp_msg	Status messages display 0 = off 1 = on	Numerical, whole number
h2o2_prozess	H2O2 process 0 = via H2O2 water 1 = process with evaporated H2O2	Numerical, whole number

## Elements in version.xml

XML tag	Description	Type
firmware_version	Base element. Contains the child element version	
version	Firmware version:	ASCII, 6 characters

## Elements in viewchannels.xml

XML tag	Description	Type
view_channels	Base element. Contains the child elements number_values, view_channel	
number_values	See general elements	
view_channel	Parent element. Contains the child elements channel_info, measurement_value, meas_status	
channel_info	Parent element. Contains the child elements connector_info, channel_type	

XML tag	Description	Type
measurement_value	See general elements	
meas_status	Parent element. Contains the child elements min, max, mean	
connector_info	Channel (transmitter/probe)	ASCII
channel_type	Parameter details	ASCII
min.	Minimum reading	Numerical, decimal number
max.	Maximum reading	Numerical, decimal number
mean	Mean value	Numerical, decimal number

**production\_options description**

Content of production\_options is a double word type number (32 bit). The individual hardware options are bit-coded here.

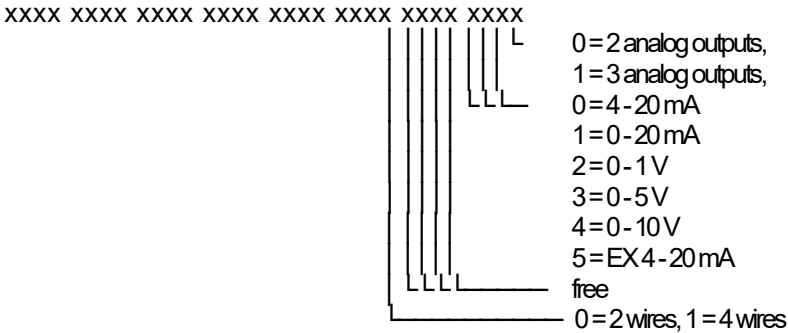

**device\_options description**

Content of device\_options is a double word type number (32 bit). The individual instrument options are bit-coded here.

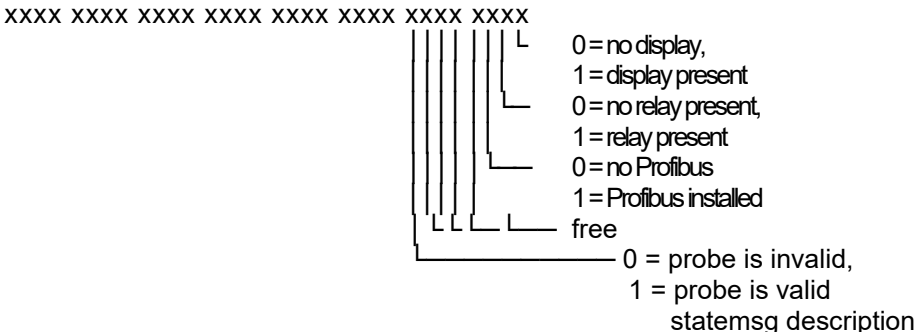

Content of statemsg is a double word type number (32 bit). The individual status messages are bit-coded here.



If statemsg = 0 there are no new messages.

If statemsg != 0:

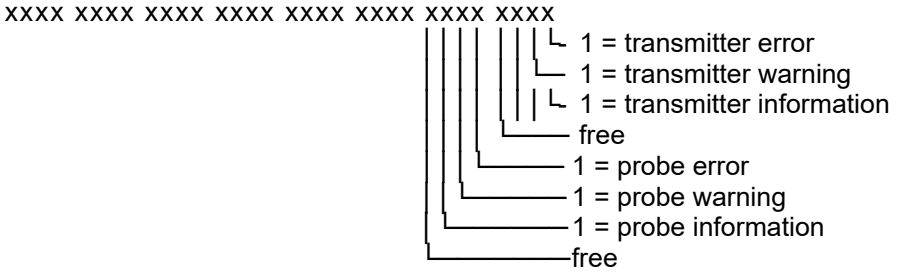

**staterel description**

Content of staterel is a double word type number (32 bit). The individual relay states are bit-coded here.

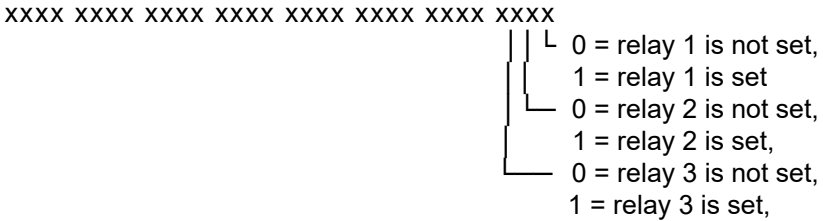

**xml files Appendix**

Note: "xxxx" = text message

**calibration.xml**

```
<?xml version="1.0" encoding="UTF-8" ?>
<calibration_data>
  <unit>%rF</unit>
  <attenuation>1</attenuation>
  <cal_offset>0.000000</cal_offset>
  <cal_scale>
    <cal_min_scale>0.000000</cal_min_scale>
    <cal_max_scale>0.000000</cal_max_scale>
  </cal_scale>
</calibration_data>
```

**collectivealarm.xml**

```
<?xml version="1.0" encoding="UTF-8" ?>
<colalarmtable>
  <alarm_numbers>4</alarm_numbers>
  <alarm>
    <alarm_event>xxxx</alarm_event>
    <alarm_state>0</alarm_state>
  </alarm>
  <alarm>
    <alarm_event>xxxx</alarm_event>
    <alarm_state>0</alarm_state>
  </alarm>
  <alarm>
    <alarm_event>xxxx</alarm_event>
    <alarm_state>0</alarm_state>
  </alarm>
  <alarm>
    <alarm_event>xxxx</alarm_event>
    <alarm_state>0</alarm_state>
  </alarm>
</colalarmtable>
```

**deviceident.xml**

```
<?xml version="1.0" encoding="UTF-8" ?>
<ident>
  <device_id>31</device_id>
</ident>
```

## firmwaredate.xml

```
<?xml version="1.0" encoding="UTF-8" ?>
<firmware_date>
  <year>2008</year>
  <month>3</month>
  <day>28</day>
</firmware_date>
```

## heatertime.xml

```
<?xml version="1.0" encoding="UTF-8" ?>
<heatertime>
  <heatertimeoff>60</heatertimeoff>
</heatertime>
```

## hourscount.xml

```
<?xml version="1.0" encoding="UTF-8" ?>
<hourcount>
  <hours>68</hours>
</hourcount>
```

## identification.xml

```
<?xml version="1.0" encoding="UTF-8" ?>
<ident>
  <device_id>31</device_id>
</ident>
```

## laststatusmessage.xml

```
<?xml version="1.0" encoding="UTF-8" ?>
<mufmsg>
  <msg>xxxx</msg>
  <serialnumber>00123456</serialnumber>
  <hours>163</hours>
</mufmsg>
```

## onlinevalue.xml

```
<?xml version="1.0" encoding="UTF-8" ?>
<online_values>
  <number_values>3</number_values>
  <measurement_value>
    <value>23.7</value>
    <unit>°C</unit>
  </measurement_value>
```

```
<measurement_value>
  <value>42.4</value>
  <unit>%rF</unit>
</measurement_value>
<measurement_value>
  <value>9.5</value>
  <unit>td°C</unit>
</measurement_value>
</online_values>
```

options.xml

```
<?xml version="1.0" encoding="UTF-8" ?>
<options>
  <device_options>00000011</device_options>
  <production_options>xxxx</production_options>
</options>
```

redefinition.xml

```
<?xml version="1.0" encoding="UTF-8" ?>
<relay_data>
  <relay_channel>0</relay_channel>
  <relay_number>0</relay_number>
  <relay_status>0</relay_status>
  <sw_point_charact>0</sw_point_charact>
  <sw_point_value>0.0</sw_point_value>
  <hysteresis_value>0.0</hysteresis_value>
</relay_data>
```

serialnumber.xml

```
<?xml version="1.0" encoding="UTF-8" ?>
<serialnumber>
  <number>0012345</number>
</serialnumber>
```

## xml files Appendix

```
<!ELEMENT serialnumber (number)>
<!ELEMENT number (#PCDATA)>
```

```
<!ELEMENT ident (device_id)>
<!ELEMENT device_id (#PCDATA)>
```

```
<!ELEMENT firmware_version(version)>
<!ELEMENT version (#PCDATA)>
```

```
<!ELEMENT firmware_date (year, month, day)>
<!ELEMENT year (#PCDATA)>
<!ELEMENT month (#PCDATA)>
<!ELEMENT day (#PCDATA)>
```

```
<!ELEMENT channel_info (connector_info, channel_type)>
<!ELEMENT connector_info (#PCDATA)>
<!ELEMENT channel_type (#PCDATA)>
```

```
<!ELEMENT online_values (number_values, (measurement_value)*)>
<!ELEMENT number_values (#PCDATA)>
<!ELEMENT measurement_value (value, unit)>
<!ELEMENT value (#PCDATA)>
<!ELEMENT unit (#PCDATA)>
```

```
<!ELEMENT view_channels (number_values, (view_channel)*)>
<!ELEMENT view_channel (channel_info, measurement_value,
meas_status)>
<!ELEMENT meas_status (min, max, mean)>
<!ELEMENT min (#PCDATA)>
<!ELEMENT max (#PCDATA)>
<!ELEMENT mean (#PCDATA)>
```

```
<!ELEMENT hourcount (hours)>
<!ELEMENT hours (#PCDATA)>
```

```
<!ELEMENT usersettings (pressure, h2o2, setting_display, backlight,
contrast, language, disp_msg, h2o2_prozess)>
<!ELEMENT pressure (#PCDATA)>
<!ELEMENT h2o2 (#PCDATA)>
<!ELEMENT setting_display (#PCDATA)>
<!ELEMENT backlight (#PCDATA)>
```

```
<!ELEMENT contrast (#PCDATA)>
<!ELEMENT language (#PCDATA)>
<!ELEMENT disp_msg (#PCDATA)>
<!ELEMENT h2o2_prozess (#PCDATA)>

<!ELEMENT calibration_data (unit, attenuation, cal_offset, cal_scale)>
<!ELEMENT attenuation (#PCDATA)>
<!ELEMENT cal_offset (#PCDATA)>
<!ELEMENT cal_scale (cal_minscale, cal_maxscale)>
<!ELEMENT cal_minscale (#PCDATA)>
<!ELEMENT cal_maxscale (#PCDATA)>

<!ELEMENT relay_data (relay_channel, relay_number, relay_status,
sw_point_character, sw_point_value, hysteresis_value)>
<!ELEMENT relay_channel (#PCDATA)>
<!ELEMENT relay_number (#PCDATA)>
<!ELEMENT relay_status (#PCDATA)>
<!ELEMENT sw_point_character (#PCDATA)>
<!ELEMENT sw_point_value (#PCDATA)>
<!ELEMENT hysteresis_value (#PCDATA)>

<!ELEMENT heatertime (heatertimeoff)>
<!ELEMENT heatertimeoff (#PCDATA)>

<!ELEMENT options (device_options, production_options)>
<!ELEMENT device_options (#PCDATA)>
<!ELEMENT production_options (#PCDATA)>

<!ELEMENT colalarmtable (alarm_numbers, (alarm)*)>
<!ELEMENT alarm_numbers (#PCDATA)>
<!ELEMENT alarm (alarm_event, alarm_state)>
<!ELEMENT alarm_event (#PCDATA)>
<!ELEMENT alarm_state (#PCDATA)>

<!ELEMENT mufstatus (statemsg, staterel, statecounter, reserved)>
<!ELEMENT statemsg (#PCDATA)>
<!ELEMENT staterel (#PCDATA)>
<!ELEMENT statecounter (#PCDATA)>

<!ELEMENT mufmsg (msg, sn, hours)>
<!ELEMENT msg (#PCDATA)>
<!ELEMENT sn (#PCDATA)>
<!ELEMENT hours (#PCDATA)>
```

**status.xml**

```
<?xml version="1.0" encoding="UTF-8" ?>
<mufstatus>
  <statemsg>0</statemsg>
  <staterel>0</staterel>
  <statecounter>1</statecounter>
</mufstatus>
```

**usersettings.xml**

```
<?xml version="1.0" encoding="UTF-8" ?>
<usersettings>
  <pressure>1013.0</pressure>
  <h2o2>0.0</h2o2>
  <setting_disp>1</setting_disp>
  <backlight>3</backlight>
  <contrast>5</contrast>
  <language>0</language>
  <disp_msg>1</disp_msg>
  <h2o2_prozess>0</h2o2_prozess>
</usersettings>
```

**version.xml**

```
<?xml version="1.0" encoding="UTF-8" ?>
<firmware_version>
  <version>V1.10</version>
</firmware_version>
```

**viewchannels.xml**

```
<?xml version="1.0" encoding="UTF-8" ?>
<view_channels>
  <number_values>2</number_values>
  <view_channel>
    <channel_info>
      <connector_info>Probe</connector_info>
      <channel_type>Temperature</channel_type>
    </channel_info>
    <measurement_value>
      <value>23.7</value>
      <unit>°C</unit>
    </measurement_value>
    <meas_status>
      <min>23.6</min>
      <max>23.7</max>
      <mean>23.7</mean>
    </meas_status>
  </view_channel>
  <view_channel>
    <channel_info>
      <connector_info>Probe</connector_info>
      <channel_type>Humidity</channel_type>
    </channel_info>
    <measurement_value>
      <value>42.5</value>
      <unit>%rF</unit>
    </measurement_value>
    <meas_status>
      <min>41.7</min>
      <max>43.0</max>
      <mean>43.0</mean>
    </meas_status>
  </view_channel>
</view_channels>
```



## 1.3.5 Adjusting the instrument

The testo adjusting concept allows the entire signal chain from the sensor signal (probe) and the digital signal (within the transmitter) through to the analog signal (transmitter output signal) to be adjusted (see diagram).

### 1-point adjustment

### 2-point adjustment

### Analog adjustment

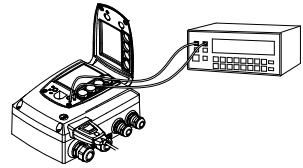
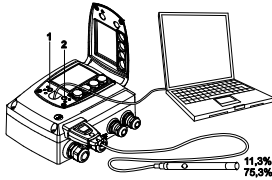

Adjustment via

- P2A software
- User menu

Adjustment 11.3 % RH and  
75.3 % RH via

- Adjustment keys (1, 2)
  - P2A software
- Adjustment 20 % rH and  
80 % rH via
- User menu

Adjustment using a precise  
multimeter and transmission  
of analog reference value in

- P2A software or
- User menu

Either the 1-point adjustment or 2-point adjustment is suitable for adjusting the sensor signal - digital signal chain.

The testo 6681 transmitter has digital probes whose adjustment information is stored in the probes' internal memory. Both 1-point and 2-point adjustments can thus be carried out on another testo 6681 (e.g. in the calibration laboratory).

### 1.3.5.1 Overview: Adjustment keys and test contacts

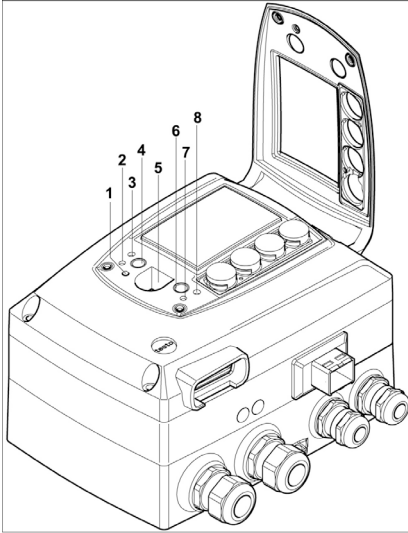

- 1 Status LED
- 2 Contact ch. 1 +
- 3 Contact ch. 1 -
- 4 Adjust key 11.3 %
- 5 Service interface
- 6 Adjust key 75.3 %
- 7 Contact ch. 2 +
- 8 Contact ch. 2 -

### 1.3.5.2 1-point adjustment (Offset)

In the 1-point adjustment, the reading at the working point is raised to the reference value so that there is no longer any deviation in the working point. The reference condition can be measured using a precise reference device or be created in an air conditioning cabinet.

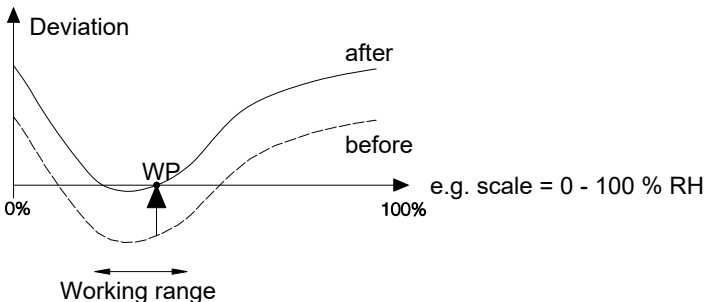

The advantage of the 1-point adjustment is the good measuring result in the working range. But the further away the measurement is from the working point, the greater the deviation can become. The 1-point adjustment should therefore only be used for a relatively narrow measuring range (working range), e.g. clean room applications, air conditioning applications for storage and similar.

The 1-point adjustment can be performed

- via the user menu (see *chapter 1.4.6.9*) or
- via the P2A software (see volume 2, chapter 3).



Please note that the 1-point adjustment is generally performed on the basis of the % RH and °C/°F parameters.

### 1.3.5.3 2-point adjustment

With the 2-point adjustment, the parameter is adjusted to the reference value at the two standard adjustment points 11.3 % RH and 75.3 % RH or 20 % RH and 80 % RH. The reference conditions are created either by using Testo humidity adjustment set (order no. 0554 0660, only for adjustment points 20 %RH and 80 %RH) or in the humidity generator.

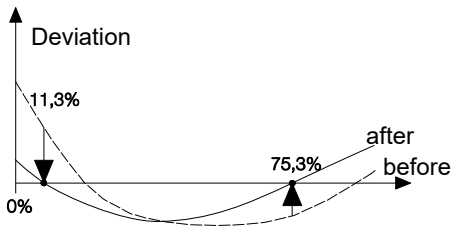

In the 2-point adjustment, the deviations between the reading and the nominal value are minimized across the entire measuring range. The 2-point adjustment is therefore recommended for large working ranges, e.g. in drying processes.

The 2-point adjustment can be performed

- via P2A software (see volume 2, chapter 3) or
- using the adjustment keys under the service flap, see description of how to proceed below.

The 2-point adjustment for the adjustment points 20 %RH and 80 %RH is carried out via the user menu.



A 2-point adjustment cancels any previous 1-point adjustment.



Adjustment with the standard Testo adjustment salt pots is not suitable for the testo 6614 (heated for high-humidity applications) and testo 6615 (trace humidity) probes. The reference conditions should be generated in a humidity generator to adjust these probes.

In addition, these probes can also be adjusted at a third adjustment point by Testo Service.

- testo 6614: third adjustment point at 90 % RH
- testo 6615: third adjustment point at -40 °Ctd/-40 °Ftd.

### ➤ Adjusting testo 6681 using adjustment keys



The 2-point adjustment for the adjustment points 20 %RH and 80 %RH is carried out via the user menu.

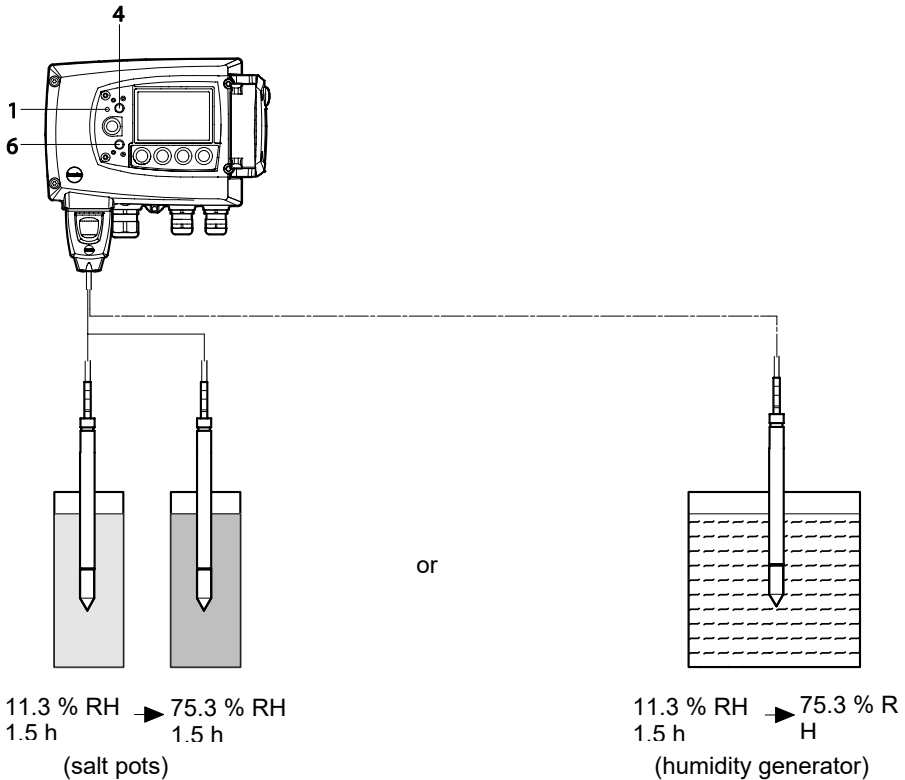

✓ The service flap of the testo 6681 is open.

- 1 Expose the humidity probe of the testo 6681 to the reference condition of 11.3 % RH for at least 1.5 hours at 25 °C.
- 2 After this equalization period, press the 11.3 % adjustment key (**4**) for at least 10 seconds with something like a ball-point pen that is not too sharp. The LED (**1**) flashes when the adjustment process begins. At the same time, the **2-point adjustment 11.3 %** status message appears on the display

Completion of the adjustment is signalled by the LED **(1)** coming on permanently and the **Probe reset** status message is shown.

- Carry out the adjustment analogously for the reference condition 75.3 % RH. Press on the 75.3 % RH adjustment key **(6)** to do this.

**3** Close the service flap.

### 1.3.5.4 Analog output adjustment

The purpose of adjusting the analog outputs is to adjust the signal chain from the digital signal (within the transmitter) to the analog outputs. The signal type that was appointed for the transmitter is adjusted respectively for each channel (e.g. 4 to 20 mA or 0 to 1 V, etc.)

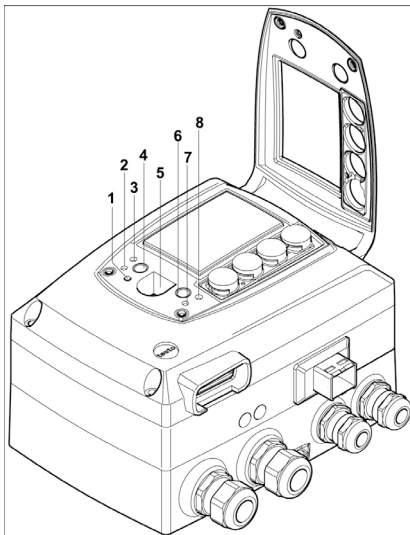

- 1 Status LED
- 2 Contact ch. 1 +
- 3 Contact ch. 1 -
- 4 Adjust key 11.3 %
- 5 Service interface
- 6 Adjust key 75.3 %
- 7 Contact ch. 2 +
- 8 Contact ch. 2 -

➤ **Analog outputs 1 and 2 adjusted**

- ✓ A precise multimeter (minimum resolution of 6.5 digits, accuracy of 100  $\mu$ A, e.g. Agilent 34401A) is available.



If only a simple multimeter is available, the analog outputs may not be adjusted.

- ✓ The service flap is open.
  - 1 Connect the inputs of the multimeter with the contacts **(2)** and **(3)** for channel 1 or with contacts **(7)** and **(8)** for channel 2.
  - 2 Transfer the reference analog value measured with the multimeter to the P2A software (see *volume 2, chapter 3*) or enter it via the user menu (see *chapter 1.4.6.9*).
  - 3 Disconnect connections between multimeter and contacts of the testo 6681 and close service flap.

➤ **Adjusting analog output 3 (optional)**



If the optional third analog output is to be adjusted, a cable connection to measure the analog value must be installed. Do this by proceeding as follows:

- 1 Open transmitter (see *chapter 1.3.3*).
- 2 Connect measuring cable to the terminals of the third analog output and guide through the cable coupling and out of the transmitter.
- 3 Reassemble upper part of transmitter.
- 4 Connect cable ends to the inputs of the multimeter.
- 5 Transfer the reference analog value measured with the multimeter to the P2A software (see *volume 2, chapter 3*) or enter it via the user menu (see *chapter 1.4.6.9*).
- 6 Remove the upper part of the transmitter, detach the cable connections for the adjustment of the 3rd analog output and reassemble the transmitter.

### 1.3.5.5 High-humidity adjustment for testo 6614

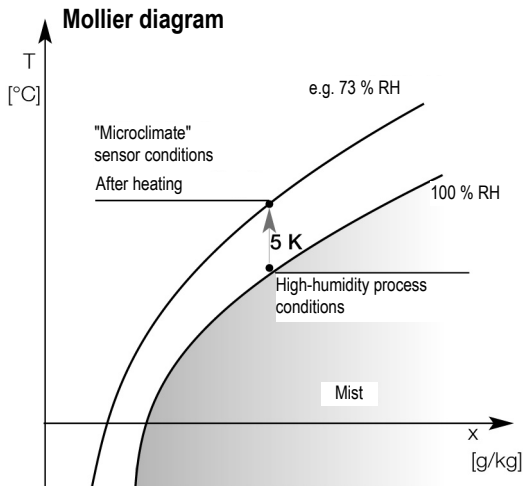

With the testo 6614, the rear of the Testo humidity sensor is heated, creating a microclimate around the sensor (within the filter) that is constantly 5 K warmer than the actual process conditions. As can be seen in the Mollier diagram, this reduces the relative humidity at the sensor from around 100 % RH to a lower value, e.g. 73 % RH. In this range, the reaction time of the sensor is noticeably shorter than in the condensation range and the risk of the sensor corroding is also reduced. Using the separate temperature probe, the testo 6681 transmitter compensates the microclimate conditions and displays the process readings.



The reference conditions (11.3 % RH and 75.3 % RH) for the 2-point adjustment of the testo 6614 should be generated in a humidity generator, as humidity adjustment sets cannot be used due to the heat generated. The adjustment can also be carried out at a third adjustment point (90 % RH) by Testo Service so that optimum accuracy is also achieved in the high humidity ranges.



### 1.3.5.6 Self adjustment of testo 6615 trace humidity probe

Conventional trace humidity probes show a steep rise in measuring uncertainty at low humidities. In the trace humidity probe of the testo 6615, these measuring uncertainties are corrected by means of an automatic self-adjustment process. This means that extremely accurate measuring results are also attained to  $-60\text{ °Ctd}$ .

To this end, a temperature sensor is fitted on the back of the testo 6615 which is used as a heater. A humidity and temperature value pair is taken in both the unheated and heated state. The deviation of the probe obtained from these pairs of values is automatically corrected.

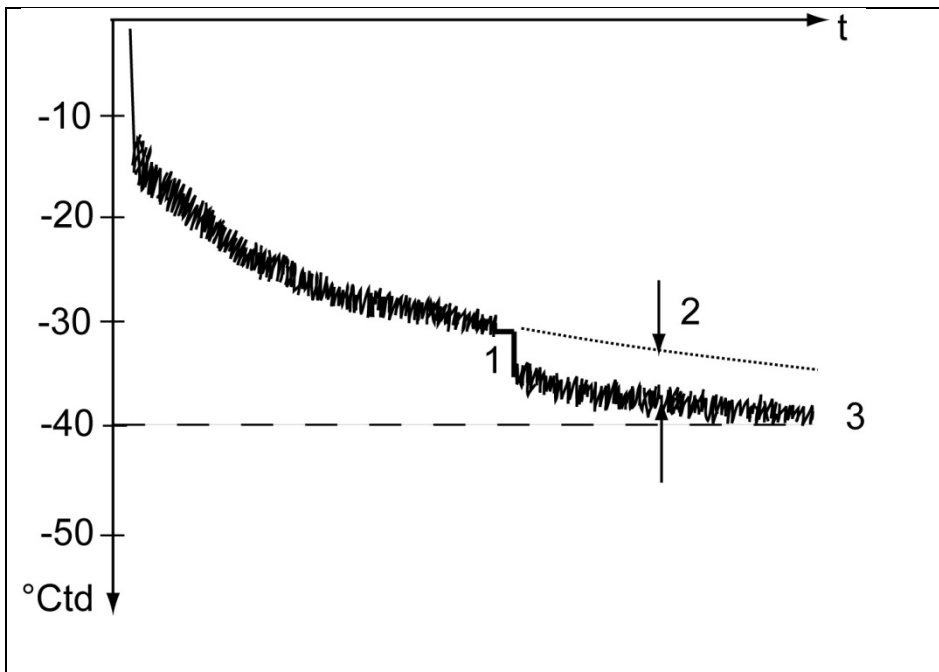

The graph shows the effect of the self-adjustment, e.g. during the Init. phase.

- 7 Self-adjustment
- 8 Correction of measurement value
- 9 Process dew point temperature

For the effectiveness of the self-adjustment the following prerequisites are decisive over the duration of the self-adjustment.

- The process temperature should not vary by more than 0.5K
- The dew point temperature should remain stable, as far as possible
- The process pressure should not vary excessively



If these prerequisites cannot be fulfilled, the values obtained during the last successful self-adjustment will be maintained.

All adjustment processes are saved in the history of the transmitter, see chapter 3.3.5 Transmitter history.

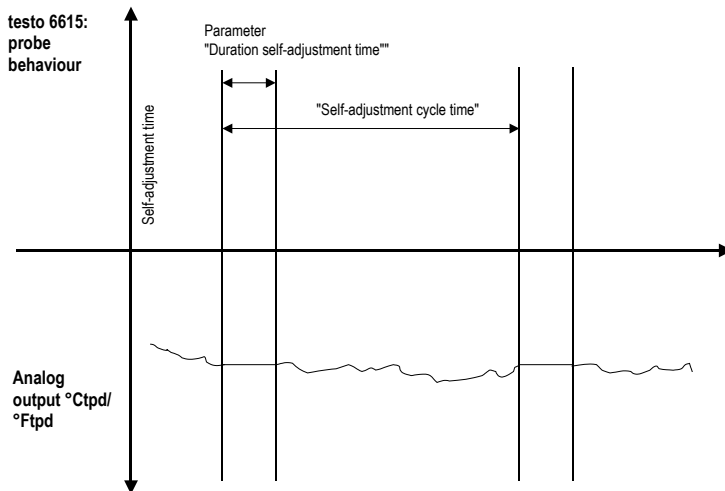

The heating time and storing of cycles can be edited in the P2A software; for example, they can be deactivated by setting the two parameters to "0".



Important:

- Deactivating the adjustment function of the testo 6615 will reduce measuring accuracy and should therefore be restricted to the shortest possible length of time.
- During the heating phase, the relay and analog outputs, the display value and output value are "frozen", see diagram above. **Self-adjustment active** is shown in the display until it has finished. The factory setting for self-adjustment time (incl. heating time, calculation time, cooling time) requires 30 minutes daily. The cycle time can be edited via the operating menu or the P2A software.
- In the factory setting, a **third adjustment point** (-40 °Ctd) is approached for the testo 6615 in addition to the 2-point adjustment.  
This special adjustment can be performed again by your Testo Service team if necessary.

## 1.4 Operation

### 1.4.1 Relationship between user menu and mini-DIN socket is active

The testo 6681 can be parameterized using either the user menu or the P2A software (see *volume 2, chapter 2*).



The testo 6681 humidity transmitter can only be operated via the display and keypad if the display option is available.

If the testo 6681 is connected to the P2A software, the user menu is blocked for the duration of the communication. The message **Service plug** is shown in the display of the testo 6681. As soon as the P2A software is disconnected, the user menu is accessible again.

## 1.4.2 Key cover

To prevent unauthorized operation of the keys, the standard key frame can be replaced with a key cover.

If the key cover has been assembled, the service flap must be opened for operation (see Section *Opening the instrument*, chapter 1.3.3).

### ➤ Attaching the key cover

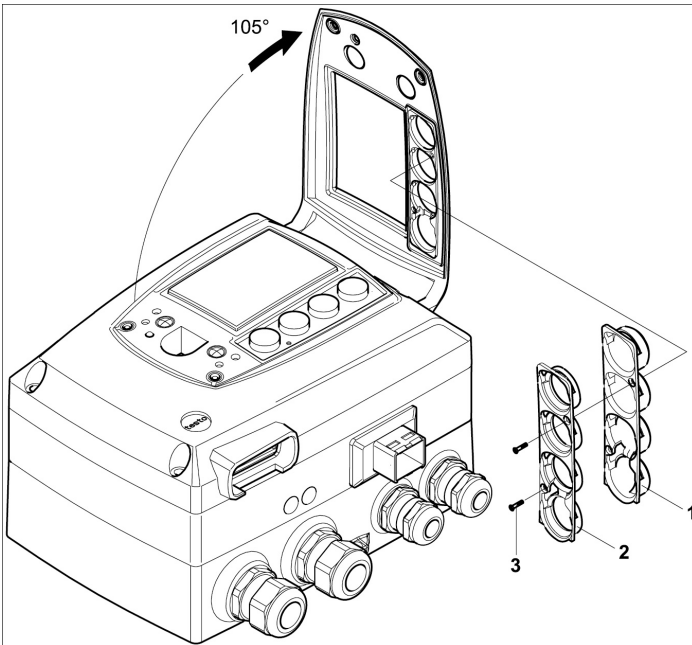

✓ The service flap is open, see *Opening the instrument*, chapter 1.3.3.

- 1 Undo screws (3) and remove key frame (2).
- 2 Insert key cover (1) into service flap and tighten screws (3).
- 3 Close and screw down the service flap.

### 1.4.3 Password protection

The user menu can be protected with a four-digit numerical code (see *Editing Main Menu Settings, chapter 1.4.6.5*) so that access to the user menu is denied to unauthorized persons not familiar with this numerical code.

If the password protection is not to be used, the numerical code "0000" must be entered. This is also the status upon delivery.

### 1.4.4 Structure of user menu

At the main menu level, the user menu comprises the following:

- **Main menu of channel 1**
- **Main menu of channel 2**
- **Main menu of channel 3 (if this option is available)**
- **Main Menu Alarm**
- **Editing Settings main menu**
- **Analysis main menu**
- **Main Menu Messages**
- **Ident main menu**
- **Adjustment main menu**
- **Reset main menu**

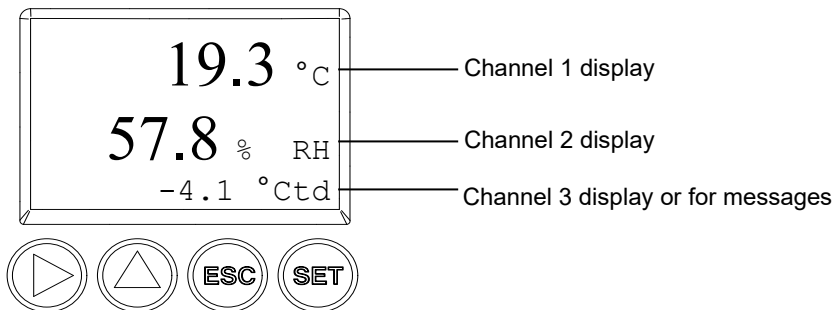

Four keys enable the user to navigate/scroll through the menus and enter/amend values and settings:

<b>Key</b>	<b>Function/description</b>
SET	- In Measuring Mode: changes to parameterization - In Parameterizing Mode: confirms a selection or setting
ESC	- Leaves a menu (without modifying any settings)
▶	- Selecting: scrolls through menus (downwards) or selectable alternatives - Editing: changes to next digit (to the right)
▲	- Selecting: scrolls through menus (upwards) or selectable alternatives - Editing: increases the value of the current digit by 1

# 1.4.5 Overview of the testo 6681 user menu

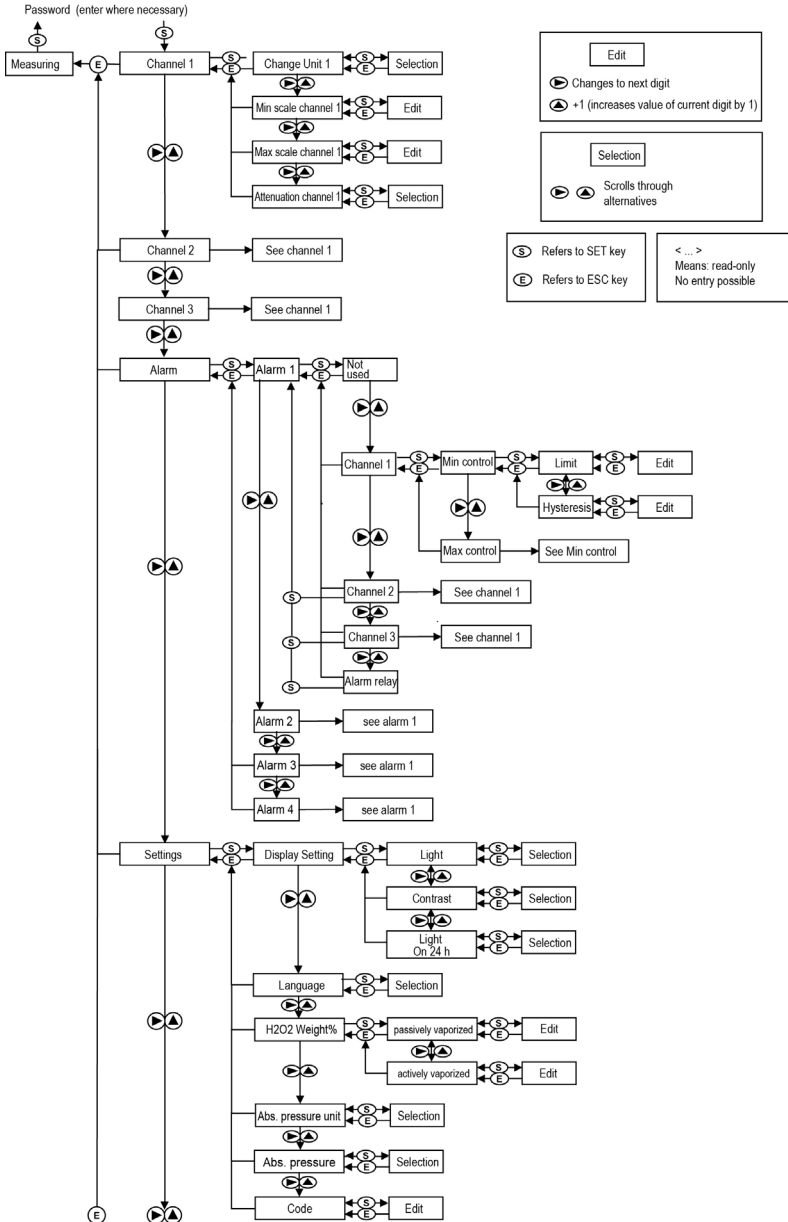

# 72 testo 6681 Ethernet - 1.4 Operation

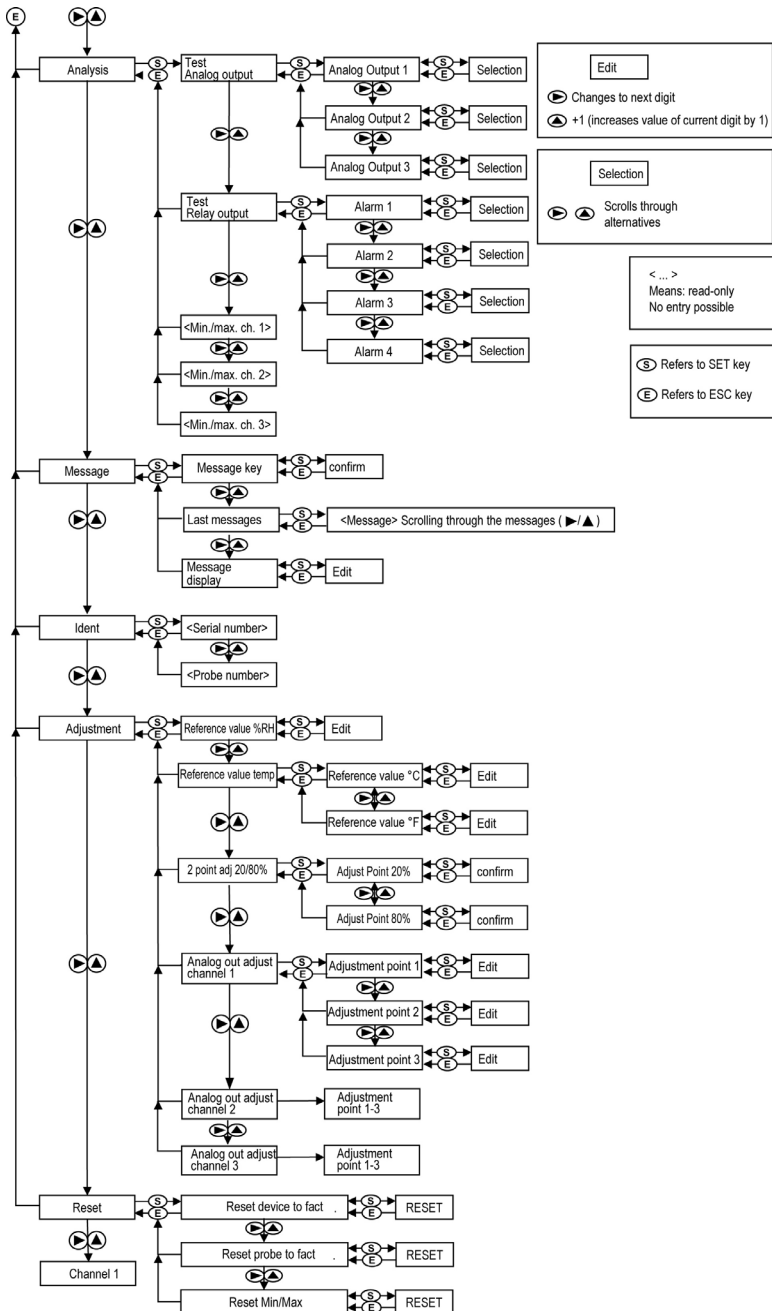



## 1.4.6 The individual main menus

### 1.4.6.1 Editing main menu of channel 1

An overview is given in *Overview of the testo 6681 user menu, chapter 1.4.5*).

You can perform basic settings for channel 1.

- 1 In Measuring Mode, press SET, select **Main Menu Channel 1** using ► or ▲ and confirm selection with SET.

One of the following parameters can now be selected using ► or ▲, after which the selection must be confirmed with SET:

- **Channel 1 unit**

The parameter for this channel is selected.

Selection: % RH, °C, °F, °Ctd, °Ftd, g/m<sup>3</sup>, gr/ft<sup>3</sup>, g/kg, gr/lb, kJ/kg, BTU/lb, °Ctw, °Ftw, "H<sub>2</sub>O, hPa, ppm<sub>vol</sub>, % Vol, °Ctm, °Ftm.

Edit/select parameter with ► or ▲, confirm with SET or abort input with ESC.

- **Scale minimum for channel 1**

The lower scale limit is edited;

Unit as selected above (example: 4 mA = 0 % RH).

Editing the value: Scroll one digit to the right using ►, increase value of digit by 1 using ▲. Confirm with SET or abort entry with ESC.

- **Scale maximum for channel 1**

The upper scale limit is edited;

Unit as selected above (example: 20 mA = 100 % RH).

Editing the value: Scroll one digit to the right using ►, increase value of digit by 1 using ▲. Confirm with SET or abort entry with ESC.

- **Signal delay ("Damping") for channel 1**

The analog signal can be delayed ("Damping"); a time constant is selected for this (1 = no delay; 15 = longest delay).

Edit/select parameter using ► or ▲, confirm with SET or cancel entry via ESC.

- 2 Continue to **Main Menu Channel 2** using ► or ▲ or return to Measuring Mode by pressing ESC.

### 1.4.6.2 Editing main menu of channel 2

See channel 1.

### 1.4.6.3 Editing main menu of channel 3 (if this option is available)

See channel 1.

#### 1.4.6.4 Editing Main Menu Alarm

With the alarm, the relays, available as options, are programmed. In addition, the alarm statuses are shown on the display (top right) (even without relays). You can choose whether the alarm is to be used to monitor limit values or as a collective alarm. If an alarm is to be used to monitor limit values, you can choose between monitoring the minimum or maximum value and set a limit value and hysteresis for each alarm.

- 3 In Measuring Mode, press SET, select **Main Menu Alarm** using ► or ▲ and confirm selection with SET.

Four alarms can be parameterized.

- 4 Select **Alarm x** using ► or ▲ and confirm selection with SET.

➤ **Using alarm to monitor limit values**

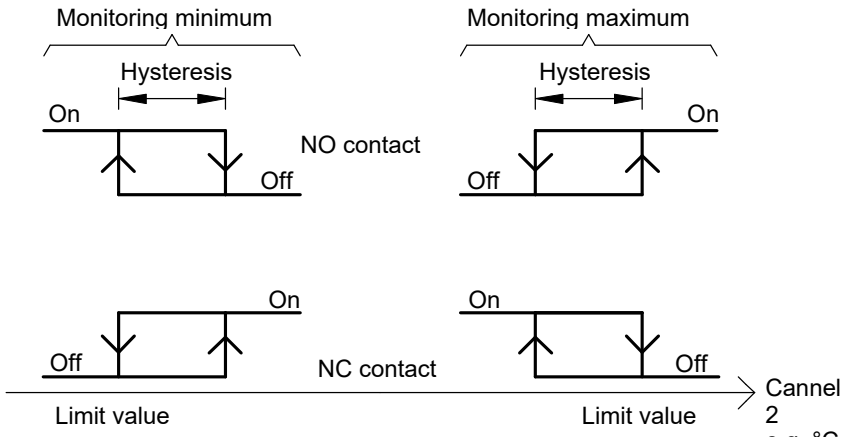

- 1 Select **Channel x** (e.g. "Channel 1") using ► or ▲ and confirm selection with SET.
- 2 Select **Max control** or **Min control** with ► or ▲ (see graphic).
- 3 Press SET and edit **limit value** and **hysteresis**: Scroll one digit to the right using ►, increase value of digit by 1 using ▲. Confirm with SET or abort entry with ESC.
- 4 Return to **Channel x** by pressing ESC.
- 5 Return to **Alarm x** by pressing ESC.
- 6 Change to the other relays using ► or ▲ and perform settings in the same way.

➤ **Using alarm as collective alarm or not using it at all**

If the collective alarm is assigned to an alarm, the relay is switched as soon as (at least) one of the warning or error messages of the testo 6681 transmitter (or the connected testo 6610 probe) is activated.



Note:

The messages affecting the collective alarm can only be selected in the P2A software, see *volume 2, chapter 2*.

- ✓ Alarm is selected (see previous steps 1 and 2).
- 1 Specify with ► or ▲ whether **Alarm x** is to be used as the **Alarm relay** or is to be **not used**. Confirm selection with SET and return to **Alarm x**.

- 2 Change to another alarm using ► or ▲ and perform settings in the same way.
- 3 Continue to **Main Menu Settings** using ► or ▲ or return to Measuring Mode by pressing ESC.

### 1.4.6.5 Editing Main Menu Settings

You can edit instrument settings and other settings.

In Measuring Mode, press SET, select **Main Menu Settings** using ► or ▲ and confirm selection with SET.

You can edit settings for:

- Display
- Language
- H2O2 proportion by weight entry (optional with 3rd analog output)  
Unit: %
- Absolute pressure unit  
Selection: bar, psi, mPa, hPa
- Absolute pressure  
Unit as selected above.
- Code

#### ➤ Editing display settings

You can set the brightness and contrast of the display.

- 1 Select **Display Settings** using ► or ▲ and confirm selection with SET.
- 2 Select **Backlight** or **Contrast** using ► or ▲ and confirm selection with SET.

One of the following parameters can now be selected using ► or ▲, after which the selection must be confirmed with SET:

- **Backlight**  
The display illumination is changed.  
Edit/select parameter with ► or ▲, confirm with SET or cancel entry with ESC (the effect of the change in parameter can be seen during input).
- **Contrast**  
The brightness difference between the display background and the displayed values is changed.

Edit/select parameter with ► or ▲, confirm with SET or cancel entry with ESC (the effect of the change in parameter can be seen during input).

• **Backlight on 24 h**

Using ► or ▲ select **On** or **Off** and confirm with SET.

- Off: The display light switches off automatically if no button was pressed for 30 seconds.
- On: The display light is activated

3 Go back to **Display Settings** by pressing ESC and continue to **Language** using ► or ▲.

➤ **Selecting language**

You can select the language for the plain text line in the display.

- Press SET, select required language with ► or ▲, confirm selection with SET and return to **Language**.



Only choose a language that you can understand well.

➤ **Editing H<sub>2</sub>O<sub>2</sub> proportion by weight (optional with 3rd analog output)**

This menu is only used to parameterize humidity measurements in H<sub>2</sub>O<sub>2</sub> atmospheres (e.g. in sterilization processes) and determines whether °Ctm, °Ftm or %rFm is the output parameter.

4 Select **H<sub>2</sub>O<sub>2</sub> Weight Proportion** using ► or ▲ and confirm selection with SET.

The selection **H<sub>2</sub>O<sub>2</sub> passively vaporized** or **H<sub>2</sub>O<sub>2</sub> actively vaporized** in the submenu describes whether H<sub>2</sub>O<sub>2</sub> is created through evaporation or is actively evaporated in the process.

5 Select **H<sub>2</sub>O<sub>2</sub> passively vaporized** or **H<sub>2</sub>O<sub>2</sub> actively vaporized** using ► or ▲ and confirm with SET.

6 Editing proportion by weight of H<sub>2</sub>O<sub>2</sub> in % (% H<sub>2</sub>O<sub>2</sub> proportion by weight in the liquid end solution): Scroll one digit to the right using ►, increase value of digit by 1 using ▲. Confirm with SET or abort entry with ESC.

7 Using ESC return to **H<sub>2</sub>O<sub>2</sub> proportion by weight** and continue to **Absolute pressure unit** using ► or ▲.

### ➤ **Selecting absolute pressure unit (Abs. pressure unit)**

This parameter determines the humidity variables, standardised atmospheric dewpoint (°CtA, °FtA), relative humidity (g/kg or gr/lb) and water content (ppm<sub>vol</sub> or % vol).

- 1 Press SET, select desired unit (selection: bar, psi, mPa, hPa) using ► or ▲ confirm selection with SET or cancel with ESC.
- 2 Continue to **Absolute Pressure** with ► or ▲.

### ➤ **Editing absolute pressure (Abs. pressure value)**

You can set a value for the process absolute pressure.

- 1 Using ► or ▲, select **Abs. pressure value** and confirm selection with SET.

The absolute pressure is displayed.

- 2 Scroll one digit to the right using ►, increase value of digit by 1 using ▲. Confirm with SET or abort entry with ESC.
- 3 Press SET and return to **Abs. pressure value**.
- 4 Return to **Main Menu Settings** by pressing ESC.
- 5 Continue to **Main Menu Analysis** using ► or ▲ or return to Measuring Mode by pressing ESC.

### ➤ **Editing code settings**

You can set the access code (password).



If a code other than "0000" (factory setting) is set, the transmitter can only be operated once this code has been entered via the menu.

- 1 Select **Code** using ► or ▲ and confirm selection with SET.
- 2 Scroll one digit to the right using ►, increase value of digit by 1 using ▲. Confirm with SET or abort entry with ESC.
- 3 Return to **Code** by pressing ESC.

### 1.4.6.6 Editing Analysis main menu

You can test the functionality of analog and relay outputs. In addition, you can read off the minimum and maximum values (since the last voltage supply or reset of the min./max. values).

#### ➤ Testing functionality of analog outputs



This function affects the analog outputs directly, not only the test contacts.

- 1 In Measuring Mode, press SET, select **Main Menu Analysis** using ► or ▲ and confirm selection with SET.

**Test Analog Output** is shown.

- 2 Press SET, choose between **Analog Output 1, 2, 3** with ► or ▲.
- 3 Press SET, scroll one digit to the right using ►, increase value of digit by 1 using ▲. Any analog output value can be predefined, e.g. for an analog output of 4 to 20 mA, the value "6.0 mA". Confirm with SET or abort entry with ESC.
- 4 Accept setting by pressing SET and test with multimeter (minimum requirement: resolution of 6.5 digits, accuracy of 100 nA):

Analog output 1 or 2: Via test contacts under service flap, see diagram.

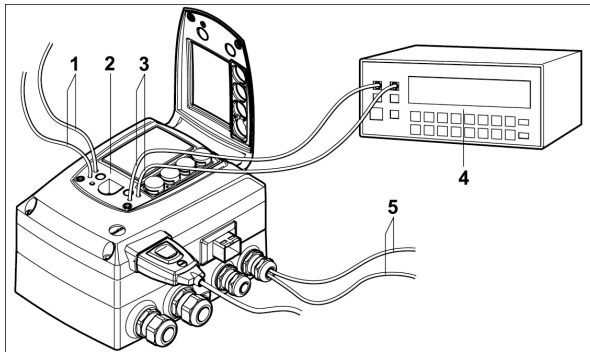

- 1 Channel 1 test contacts
- 2 Service interface
- 3 Channel 2 test contacts
- 4 Multimeter
- 5 Ends of channel 3 cables

Analog output 3: Connect measuring cables to terminals for channel 3, guide measuring cables out of housing and perform measurement outside of the transmitter, see diagram.

- 5 Return to **Test Analog Output** using ESC and continue to **Test Relay Output** using ► or ▲.

➤ **Testing functionality of relay outputs**

- 1 Press SET, choose between **Alarm 1, 2, 3, 4** with ► or ▲.
- 2 Press SET.

The relay can now be tested. You can choose between **OFF** and **ON** using ► or ▲. If **ON** is chosen, the NO contact is closed, the NC contact opened. If **OFF** is chosen, the NC contact is closed, the NO contact opened.

- 3 To test, route a measuring cable from the relay terminals (see *chapter 1.3.3.3*) out of the transmitter to a multimeter (resistance measurement) or continuity tester.
- 4 Return to **Test Relay Output** by pressing either SET (starts relay test) or ESC (exits the menu without relay test).

➤ **Reading off min./max. values of channels**



To reset the max./min. values, see chapter 1.4.6.10.

- 1 Read off the min./max. values of the three channels by pressing ► or ▲ one after the other and return to **Main Menu Analysis** using ESC.
- 2 Continue to **Main Menu Message** using ► or ▲ or return to Measuring Mode by pressing ESC.



### 1.4.6.7 Editing Message main menu

Messages can be confirmed/acknowledged, the last messages can be called up and the display of the messages can be switched on or off.

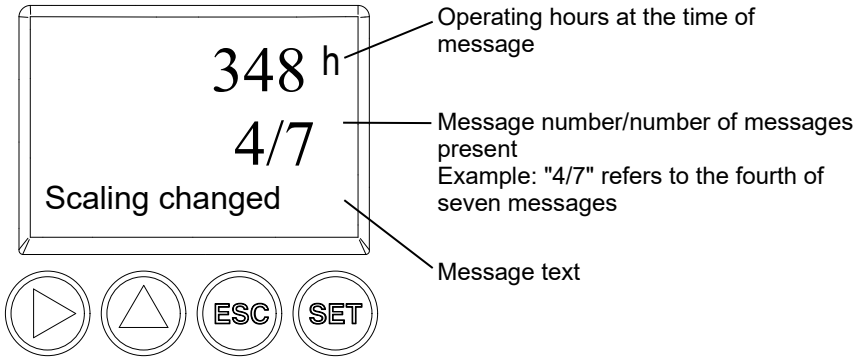

Using the P2A software (see *volume 2, chapter 3*) you can predefine which of the messages are to be shown in the display.

- 1 In Measuring Mode, press SET, select **Main Menu Message** using ► or ▲ and confirm selection with SET.
  - 2 Confirm **Confirm message** using SET.
  - 3 Select **Last messages** using ► or ▲ and confirm with SET.
  - 4 Scroll between the messages recorded so far using ► or ▲ and press ESC to return to **Last messages**.
  - 5 Continue to **Display of message** with ► or ▲.
- ON:** Measurements are shown on the display in Measuring Mode.  
**OFF:** No messages shown on display.
- 6 Select **ON** or **OFF** using ► or ▲ and confirm selection with SET.
  - 7 Return to **Main Menu Message** by pressing ESC.
  - 8 Continue to **Main Menu Ident** using ► or ▲ or return to Measuring Mode by pressing ESC.



An overview of the messages can be found in *chapter 1.5, Status, warning and error messages*.

### 1.4.6.8 Calling up Main Menu Ident

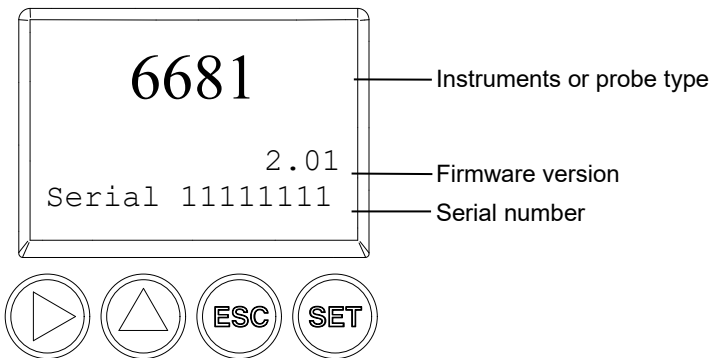

The serial numbers of the transmitter and probe can be read off.

- 1 In Measuring Mode, press SET, select **Main Menu Ident** using ► or ▲ and confirm selection with SET.

The type, firmware version and serial number of the transmitter are displayed.

- 2 Press ESC to return to the **Main Menu Ident** or read off the type, firmware version and serial number of the probe using ► or ▲ and then press ► or ▲ to return to the **Main Menu Ident**.
- 3 Continue to **Main Menu Adjustment** using ► or ▲ or return to Measuring Mode by pressing ESC.

### 1.4.6.9 Editing Adjust main menu

A reference value can be entered for both relative humidity (RH) and temperature (°C/°F) for the 1-point adjustment. Please refer to the description in *chapter 1.3.5.2*.

In addition, the analog outputs can be adjusted. See *chapter 1.3.5.4* for instructions on how to do this.



The 2-point adjustment for the adjustment points 20 %RH and 80 %RH is carried out via the user menu.

For the adjustment points 11.3 %RH and 75.3 %RH, the 2-point adjustment is carried out via the adjustment buttons or the P2A software, see *chapter 1.3.5.3* or *volume 2, chapter 3*.

➤ **Enter reference value for 1-point adjustment**



Please also refer to *chapter 1.3.5.2*.

- 1 In Measuring Mode, press SET, select **Main Menu Adjust** using ► or ▲ and confirm selection with SET.

**Reference value % RH** is displayed.

- 2 Press SET, edit value: Scroll one digit to the right using ►, increase value of digit by 1 using ▲. Confirm with SET or cancel entry with ESC.
- 3 Continue to **Reference value temp** with ► or ▲.
- 4 Press SET and **Reference value °C** is displayed.
- 5 Press SET, edit value: Scroll one digit to the right using ►, increase value of digit by 1 using ▲. Confirm with SET or abort entry with ESC.
- 6 Continue to **Reference value °F** with ► or ▲.
- 7 Press SET, edit value: Scroll one digit to the right using ►, increase value of digit by 1 using ▲. Confirm with SET or abort entry with ESC.
- 8 Continue to **Analog Adj. Ch. 1** with ► or ▲.
- 9 Continue with the adjustment of the analog outputs (see below, step 2) or press ESC to return to **Main Menu Adjustment**.
- 10 Continue to **Main Menu Reset** using ► or ▲ or return to Measuring Mode by pressing ESC.

➤ **Performing the 2-Points-Adjustment for 20% RH and 80 % RH**

- 1 In the Measuring Mode press SET, select **main menu Adjust** with ► or ▲ and confirm selection with SET.
- 2 Continue to **2Pt Adjust 20/80%** with ► or ▲.
- 3 Press SET.
- 4 Continue to **Adj. Point 20%** or **Adj. Point 80%** with ► or ▲
- 5 Confirm selection with SET.
- 6 The red LED ADJ flashes

In the display **2Pt Adjust 20/80%**, **1-point adjustment**, **Probe reset** appears consecutively.

The adjusted measurement values appear after probe reset.

➤ **Performing analog adjustment**



Please refer to *chapter 1.3.5.4*.

- 1 In Measuring Mode, press SET, select **Main Menu Adjust** using ► or ▲ and confirm selection with SET.



Each channel is adjusted at three points in the analog range (at 10 %; 50 %; 90°% of the analog scale).

- 2 Select **Analog Adj. Ch. 1** using ► or ▲ and confirm with SET.
- 3 Select **Adj. Point 1** using ► or ▲.
- 4 Press SET. Read off multimeter display (e.g. 5.601 mA) and enter this value in the user menu. Do this by scrolling one digit to the right using ► and increasing the value of digit by 1 using ▲. Confirm with SET or abort entry with ESC.
- 5 Select **Adj. Point 2** using ► or ▲.
- 6 Press SET. Read off multimeter display (e.g. 12.001 mA) and enter this value in the user menu. Do this by scrolling one digit to the right using ► and increasing the value of digit by 1 using ▲. Confirm with SET or abort entry with ESC.
- 7 Select **Adj. Point 3** using ► or ▲.
- 8 Press SET. Read off multimeter display (e.g. 18.401 mA) and enter this value in the user menu. Do this by scrolling one digit to the right using ► and increasing the value of digit by 1 using ▲. Confirm with SET or abort entry with ESC.
- 9 Continue to **Analog Adj. Ch. 2** or **3** with ► or ▲ (repeat steps 3 to 8).
- 10 Return to **Main Menu Adjust** by pressing ESC.
- 11 Continue to **Main Menu Reset** using ► or ▲ or return to Measuring Mode by pressing ESC.

### 1.4.6.10 Editing Reset main menu

You can reset the factory settings for the following:

- Instrument
- Sensor/probe
- Min./max. values



Resetting to the factory settings means resetting to the order specification, i.e. the specific condition at the time of supply to the customer.

- 1 In Measuring Mode, press SET, select **Main Menu Reset** using ► or ▲ and confirm selection with SET.

**Reset device** to factory settings is displayed.

- 2 Select the setting to be reset using ► or ▲ and confirm selection with SET.

**Reset Completed** is displayed.

- 3 Press ESC or SET to return to reset setting and press ESC to return to **Main Menu Reset**.
- 4 Continue to **Main Menu Channel 1** using ► or ▲ or return to Measuring Mode by pressing ESC.

# 1.5 Status, warning and error messages



To achieve optimum operational reliability (machine availability), the transmitter provides the following via the user menu (see *chapter 1.4*) or the P2A software (see *volume 2, chapter 2*):

- Status messages,
- Warning messages and
- Error messages

for either the testo 6681 or the connected testo 661x probe as applicable.

All messages are stored in the transmitter with an operating hours stamp. Use the user menu (see *chapter 1.4.6.7*) or P2A software (see *volume 2, chapter 2*) to view the message history.

In the transmitter, the last 160 messages are stored in a ring memory, but there is no restriction in the P2A software.

## 1.5.1 Status messages

Status messages show the current operating mode of the testo 6681.

Message	Display	Description
00300	New limit value	The limit value has been changed or shifted
00301	Scaling changed	The scaling has been changed
00500	Transmitter reset:	The transmitter was reset to the factory settings and is restarted.
0052F	Reset Min/Max	Resets all saved Min/Max values for all channels
02506	Probe connection	A probe has been connected
01D19	Service plug	The Mini-DIN socket is connected to: the USB adapter for P2A software, the adjustment adapter or the service plug (is not recorded/no number)
00307	User Setting Change	User Setting Change: General settings were changed for the transmitter.

Message	Display	Description
02d07	Probe disconnected	No probe is connected
02104	Analog out adjust	An analog adjustment has been made
02101	1-point adjustment	A 1-point adjustment is performed.
02102	2-point adjustment 11.3%	As part of the 2-point adjustment, an adjustment is performed at 11.3 % RH
02103	2-point adjustment 75.3%	As part of the 2-point adjustment, an adjustment is performed at 75.3 % RH
02120	2-point adjustment 20 %	As part of the 2-point adjustment, an adjustment is performed at 20 % RH
02130	2-point adjustment 80 %	As part of the 2-point adjustment, an adjustment is performed at 80 % RH
02105	Self-adjustment active	For testo 6615 probe only: The probe performs an automatic self-adjustment
02518	Probe reset	Probe reset: The probe performs a reset

## 1.5.2 Warning messages

Warning messages show an early warning or a current malfunction which may negatively impact measuring.

Message	Display	Cause	Remedying of fault
02101	2-point adjustment drift*	In the 2-point adjustment, corrections repeatedly occur in the same direction; this may indicate a sensor drift	Send the probe into Testo Service
00E00	T ambient high**	The ambient temperature exceeds the permissible temperature for the transmitter	Take necessary measures to lower ambient temperature, e.g. through venting or cooling
00E01	T ambient low**	The ambient temperature is below the permissible temperature for the transmitter	Take necessary measures to raise ambient temperature, e.g. through heating
00E02	Supply voltage low**	The supply voltage is below the minimum voltage required for the transmitter	Ensure sufficient voltage supply

<b>Message</b>	<b>Display</b>	<b>Cause</b>	<b>Remedying of fault</b>
00E00	T process high**	The process temperature exceeds the temperature designated for the probe	Remove the probe from the process and take any necessary measures to lower the process temperature
02806	Condensation*	100 % RH has been reached, condensation developing	Take measures to reduce process humidity
02807	Values less than 0 % RH**	The adjustment or sensor is faulty	Check adjustment (via P2A adjustment history, perform 2-point adjustment where necessary)  If the problem persists, contact Testo Service
02809	Sensor early warning*	For testo 6617 probe only: The cover electrode of the sensor is damaged; this may soon cause the sensor to break	Carry out visual inspection  If the mirror-like surface of the sensor is dirty or damaged, contact Testo Service

\* Early warning

\*\* Current malfunction



## 1.5.3 Transmitter error messages

Error messages show a current malfunction.

Message	Display	Cause	Remedying of fault
03401	No probe signal	The probe communication is interrupted	Ensure that the probe connector is fully engaged in the transmitter. If communication still cannot be established, contact Testo Service
03508	Wrong probe	The connected probe is not compatible with the present transmitter	Use a compatible probe Note: The 660x probes match the 665x transmitter, and the 661x probes the 668x transmitter
01528	Watchdog error	Due to a processor error, the transmitter performs an automatic restart	If the problem occurs frequently, contact Testo Service
0300A	% RH sensor short-circuit	Short-circuit in humidity sensor	Contact Testo Service
0300B	%RH sensor broken	The humidity sensor is damaged (sensor broken)	Contact Testo Service
0300C	T sensor short-circuit	Short-circuit in temperature sensor	Contact Testo Service
0300D	T sensor broken	The temperature sensor is damaged (sensor broken)	Contact Testo Service
03105	Self-adjustment error	For testo 6615 probe only: The automatic self-adjustment was faulty	Contact Testo Service

## 1.5.4 Status codes in cyclical service

### 1.5.4.1 Status codes for error messages

Message (Hexadecimal code)	Description	Cause
0x08	No communication	- No probe connected - Wrong probe connected - Communication with probe interrupted
0x10	No sensor signal	- Breakage of the sensor - Short-circuit humidity sensor - Short-circuit temperature sensor
0x0C	Transmitter malfunction	- Supply voltage to low - Ambient temperature to high - Ambient temperature to low - Transmitter is restarted

## 1.5.5 Handling alarm messages

Shown on the display <sup>1</sup>	Can be used for collective alarm <sup>2</sup>	Message start/end
Limit value	x	x
Scaling changed	x	x
Transmitter reset	x	x
Reset Min/Max		x
Transmitter refresh		x
Probe connection		
Service plug		
User Setting Change		x
Probe disconnected		
Analog out adjust		x
1-point adjustment	x	x
2-point adjustment 11.3%	x	x
2-point adjustment 75.3%	x	x
Probe self-adjustment	x	x
Probe reset	x	x

Shown on the display <sup>1</sup>	Can be used for collective alarm <sup>2</sup>	Message start/end
2-point adjustment drift*	x	
T ambient high**	x	
T ambient low**	x	
Supply voltage low**	x	
T process high**	x	
Condensation*	x	
Values less than 0 % RH**	x	
Sensor early warning*	x	
No probe signal	x	
Wrong probe		
Watchdog error	x	
% RH short-circuit	x	
%RH sensor broken	x	
T short-circuit	x	
T sensor broken	x	
Self-adjustment error		

- 1 If multiple messages/alarms are activated at the same time, only the last message/alarm is shown. If this is cancelled, the other messages that are still active are no longer displayed.
- 2 The message can be assigned the collective alarm function, which means that the collective alarm is activated as soon as at least one of the messages assigned to it is activated. The collective alarm can be assigned to each of the 4 optional relays. The collective alarm is then always the same, as it can only be defined once.

Execute **Confirm message** function (via control keys at transmitter):

- The message/alarm is no longer shown on the display. If multiple messages/alarms are active at the same time, all are reset simultaneously.
- If at least one message is assigned to the collective alarm, the collective alarm is reset. If the collective alarm is set on a relay, the relay is also reset, meaning switched to its neutral position.

## 1.5.6 Namur fault conditions

If the faults named in the following table occur, the analog outputs output special values that enable a general fault warning in the higher-level control system. The values correspond to the "Namur" industry standard.

Display message	Class	Analog output				
		0 - 20 mA	4 - 20 mA	1 V	5 V	10 V
No probe signal	Error	21 mA	21 mA	1.2 V	5.5 V	11 V
Wrong probe	Error	21 mA	21 mA	1.2 V	5.5 V	11 V
Watchdog error	Error	21 mA	21 mA	1.2 V	5.5 V	11 V
Values < 0 %RH	Underrange	0 mA	3.8 mA	0 V	0 V	0 V
Condensation	Overrange	20.5 mA	20.5 mA	1.2 V	5.5 V	11 V
%RH short-circuit	Error	21 mA	21 mA	1.2 V	5.5 V	11 V
%RH sensor broken	Error	21 mA	21 mA	1.2 V	5.5 V	11 V
T short-circuit	Error	21 mA	21 mA	1.2 V	5.5 V	11 V
T sensor broken	Error	21 mA	21 mA	1.2 V	5.5 V	11 V
Probe disconnected	Error	21 mA	21 mA	1.2 V	5.5 V	11 V

# 1.6 Maintenance and cleaning

## 1.6.1 Maintaining the instrument

We recommend that the adjustment and settings of the transmitter be checked at regular intervals using the

- User menu (*chapter 1.4*) or
- P2A software (*volume 2, chapter 2*)

Convenient "remote monitoring" of the transmitter can be implemented, for example by using a relay as a collective alarm (see *chapter 1.4.6.4*) whose messages are forwarded to a local alarm transmitter (horn, light) or PLC.

## 1.6.2 Cleaning the instrument

- Only clean the instrument carefully with a moist cloth.
- Do not use aggressive cleaning agents.
- Do not use any solvents
- Do not touch or damage the sensor.





